

High-Precision Magnetic Angle Sensor IC

1. Features

- AEC-Q100 Grade0 qualified
- ISO26262 ASILB qualified
- High-precision non-contact absolute rotary angle position detection
- Simple magnetic circuit design
- Wide operating temperature range: -40 °C to 150 °C
- Selectable output modes: analog output, PWM output, SAE J2716 compliant SENT output, 2-wire current-mode PSI5 (V2.3) output
- Programmable angle measurement range (up to 360°)
- Programmable linear transfer characteristics (custom 4-point / 8-point, or optional 16-segment / 32-segment equally spaced curves)
- 32-bit programmable user ID
- Differential Hall sensing for stray magnetic field immunity
- Rich on-chip diagnostic functions
- Overcurrent, overvoltage protection; undervoltage protection
- Package types: SOP8, TSSOP16, SIP3

2. Applications

- Non-contact absolute angle position detection
- Accelerator pedal position sensor
- Gear selector position detection
- Throttle Valve and EGR valve angular position detection
- Body height sensor
- Rotary switch angle position detection

3. Description

SC69411 is a differential Hall effect-based angular position sensor chip released by Semiment Technology. The chip integrates a fully differential Hall sensing matrix at the core, which detects corresponding sine and cosine position signals from an overhead S/N pole pair magnet. After being amplified by the preamplifier, the signals are sampled by the internal analog-to-digital conversion circuit. The chip's proprietary DSP circuit performs angle calculation, and finally outputs the absolute position information (0-360 degrees) of the magnet rotation through various interfaces.

SC69411 provides multiple output modes: analog output, PWM output, 4-wire digital SPI bus, digital SENT output, and 2-wire current-mode PSI5 output. The output curve can be programmed via custom 4-point / 8-point mapping or optional 16-/32-segment equally spaced linearization.

SC69411 is suitable for non-contact on-axis position detection, and is ideal for automotive applications such as accelerator pedals, electronic throttles, EGR valves, gear selectors, and body height systems.

The chip is available in three package types: SOP8, TSSOP16 and SIP3. The lead frame features matte tin plating, and the molding compound adopts halogen-free green material, fully complying with environmental protection and halogen-free requirements.

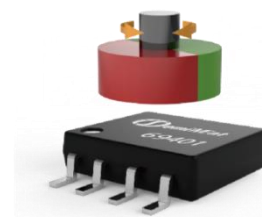

Fig.1 Product schematic diagram

CONTENTS

1. Features	1	11. Typical Application Circuit	42
2. Applications	1	12. Packaging Information	48
3. Description	1	12.1 SOP8 Package Type(DC)	48
4. Terminal Configuration	3	12.2 TSSOP16 Package Type(TG)	49
5. Ordering Information	7	12.3 SIP3 Package Type(S3)	50
6. Absolute Maximum Ratings	8	13. Packing Information	51
7. ESD Protection	8	13.1 SOP8 Tape&Reel Dimensions	51
8. Operating Characteristics	9	13.2 TSSOP16 Tape&Reel Dimensions	52
9. Block Diagram	15	13.3 SIP3 Tape&Reel Dimensions	53
10. Function Description	16	14. Revision History	54

4. Terminal Configuration

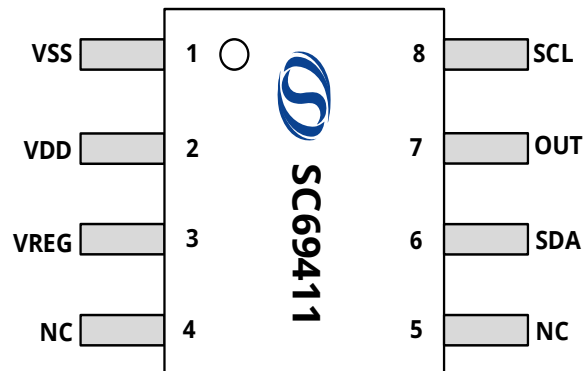

Fig.2 SOP8 Pin Description

Terminal		Type	Description
Name	Number		
VSS	1	GND	Ground
VDD	2	Power	Power supply input
VREG	3	Power Output	Internal power supply
NC	4	-	Connect to GND
NC	5	-	Connect to GND
SDA	6	Test	Test pin, connect to GND
OUT	7	Output / Digital Input	Analog output; PWM; SENT
SCL	8	Test	Test pin, connect to GND

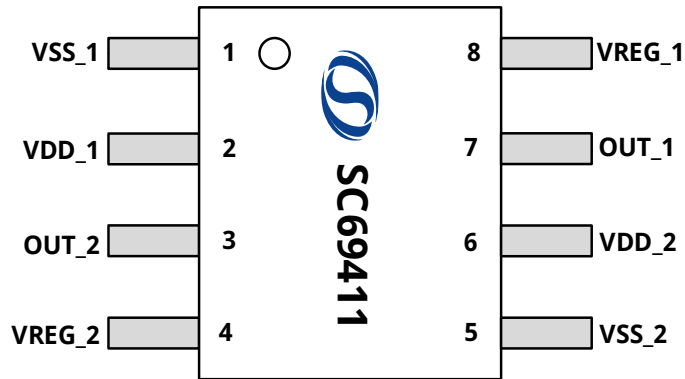

Fig.3 Dual-channel SOP8 Pin Description

Terminal		Type	Description
Name	Number		
VSS_1	1	GND	Channel 1 -- ground
VDD_1	2	Power	Channel 1 -- power supply input
OUT_2	3	Output / Digital Input	Channel 2 -- analog output; PWM; SENT
VREG_2	4	Power Output	Channel 2 -- internal power supply
VSS_2	5	GND	Channel 2 -- ground
VDD_2	6	Power	Channel 2 -- power supply input
OUT_1	7	Output / Digital Input	Channel 1 -- analog output; PWM; SENT
VREG_1	8	Power Output	Channel 1 -- internal power supply

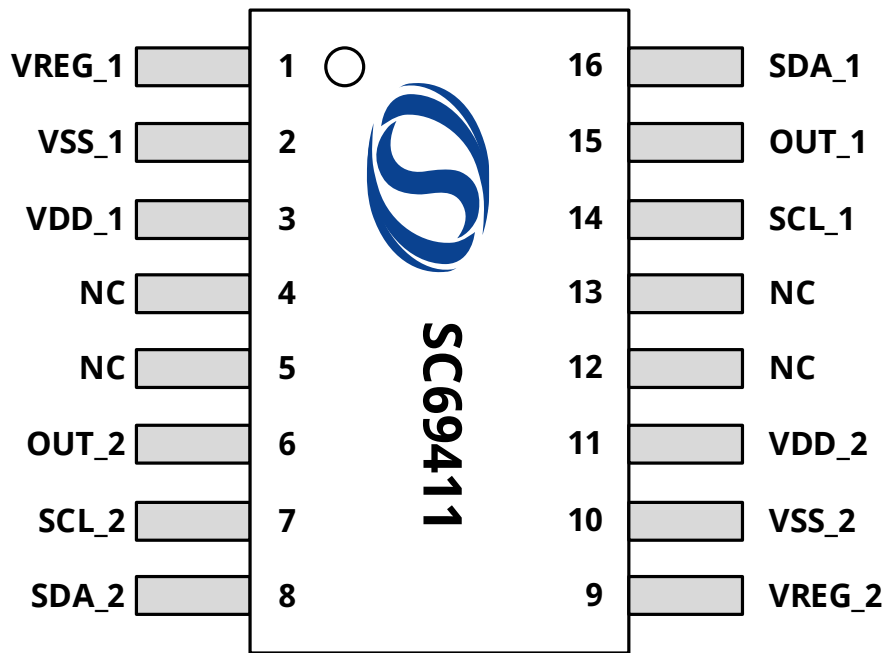

Fig.4 TSSOP16 Pin Description

Terminal		Type	Description
Name	Number		
VREG_1	1	Power Output	Channel 1 -- internal power supply
VSS_1	2	GND	Channel 1 -- ground
VDD_1	3	Power	Channel 1 -- power supply input
NC	4	—	Channel 1 -- connect to GND
NC	5	—	Channel 2 -- connect to GND
OUT_2	6	Output / Digital Input	Channel 2 -- analog output; PWM; SENT
SCL_2	7	Test	Channel 2 -- test pin, connect to GND
SDA_2	8	Test	Channel 2 -- test pin, connect to GND
VREG_2	9	Power Output	Channel 2 -- internal power supply
VSS_2	10	GND	Channel 2 -- ground
VDD_2	11	Power	Channel 2 -- power supply input
NC	12	—	Channel 2 -- connect to GND
NC	13	—	Channel 1 -- connect to GND
SCL_1	14	Test	Channel 1 -- test pin, connect to GND
OUT_1	15	Output / Digital Input	Channel 1 -- analog output; PWM; SENT
SDA_1	16	Test	Channel 1 -- test pin, connect to GND

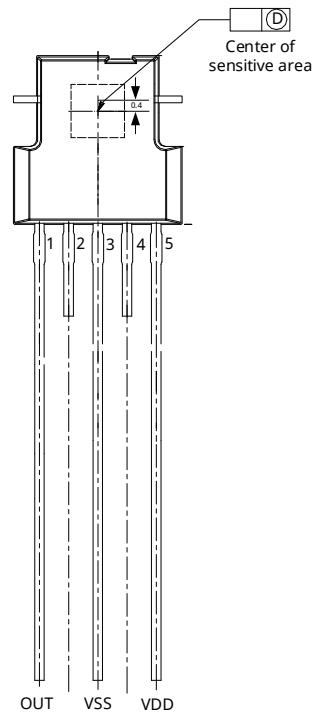

Fig.5 SIP3 Pin Description

Terminal		Type	Description
Name	Number		
OUT	1	Output	Analog output; PWM; SENT
VSS	3	GND	Ground
VDD	5	Power Input	Power supply input / PSIS-OUT

5. Ordering Information

Ordering Information	Marking	Option	Grade	Ambient, T _A (°C)	Package	Packing	Quantity
SC69411DC-000-TR-Q	69411	Analog	Q	-40~150	SOP8	Tape&Reel	4000pcs/reel
SC69411DC-PSI-TR-Q	69411	PSI	Q	-40~150	SOP8	Tape&Reel	4000pcs/reel
SC69411DA-000-TR-Q	69411	Analog	Q	-40~150	SOP8(D)	Tape&Reel	4000pcs/reel
SC69411TG-000-TR-Q	69411	Analog	Q	-40~150	TSSOP16	Tape&Reel	3000pcs/reel
SC69411S3-000-TR-Q	69411	Analog	Q	-40~150	SIP3	Tape&Reel	2600pcs/reel
SC69411S3-PSI-TR-Q	69411	PSI	Q	-40~150	SIP3	Tape&Reel	2600pcs/reel

Ordering Information Format

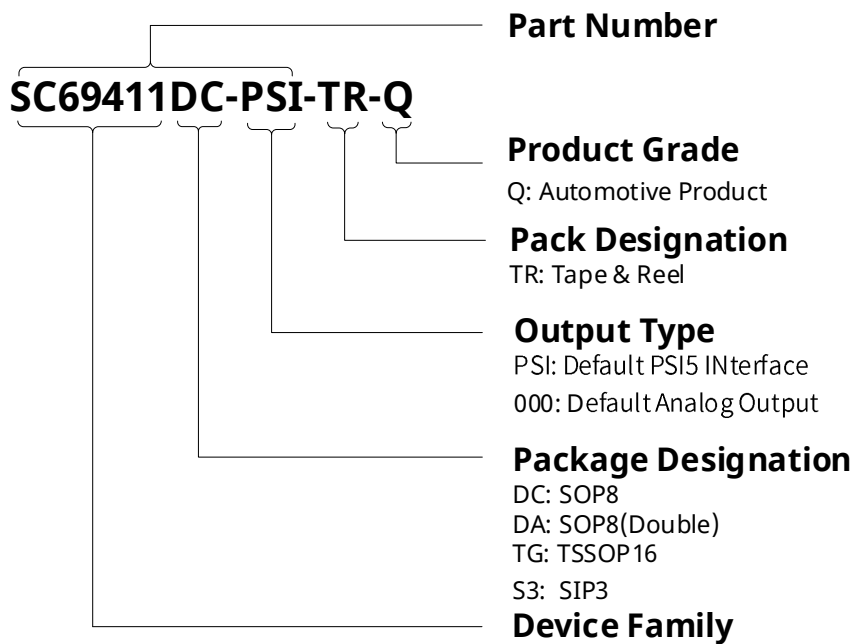

6. Absolute Maximum Ratings

Within the natural temperature range of operation (unless otherwise specified)⁽¹⁾

Symbol	Parameter	Test Conditions	Min.	Max.	Units
V _{DD}	Supply Voltage	t<48h	-14	28	V
		t<60s	-18	37	V
V _{OUT}	Analog output voltage	t<48h	-10	24	V
		t<60s	-10	30	V
I _R	SPI Output Voltage		-	40	mA
T _A	Reverse Output Current		-40	150	°C
T _S	Operating Temperature		-65	165	°C
H	Storage Temperature		-1	1	T

Note:

(1) Stresses above those listed here may cause permanent damage to the device. Exposure to absolute maximum rating conditions for extended periods may affect device reliability.

7. ESD Protection

Symbol	Parameter	Test Conditions	Min.	Max.	Units
V _{ESD_HBM}	HBM	according to standard AEC-Q100-002 HBM, R=1.5kΩ, C=100pF	-6	6	kV
V _{ESD_CDM}	CDM	according to standard AEC-Q100-011C CDM	-750	750	V

8. Operating Characteristics

Electrical Characteristics

Symbol	Parameters	Test Conditions	Min.	Typ.	Max.	Units
V_{DD}	Supply voltage	5V mode	4.5	5.0	5.5	V
$V_{DD,3.3V}$		V_{REG} and V_{DD} are connected to 3.3V at the same time, $U_{VLO_3P3EN}=1$	3.15	3.3	3.6	V
V_{DD}		PSI5	4.1	-	12	V
I_{DD}	Supply current	Single path SOP8	-	8	10	mA
I_{surge}	Isurge current	Single path SOP8	-	-	25	mA
I_{OCP}	Overcurrent alarm	Single path SOP8	-	25	35	mA
$I_{ERRSTART}$	Starting current error	PSI5	-2	-	2	mA
ΔI_S	Sink current	PSI5-Normal power mode	22	26	30	mA
		PSI5-Low power mode	11	13	15	mA
I_{SDRIFT}	Static current offset	PSI5	-4		4	mA
V_{REG}	Regulated voltage	5V mode	3.13	3.3	3.47	V
V_{REGOVP}	Regulated voltage overdrive detection	5V mode	3.5	3.7	3.89	V
V_{REGUVL}	Regulated voltage low detection	5V mode	2.8	2.9	3.0	V
$V_{DDstartH}$	Starting voltage	5V mode	3.8			V
$V_{DDstartHyst}$	Starting voltage hysteresis	5V mode		100		mV
V_{UVLO}	Undervoltage detection voltage	$U_{VLO_3P3}=0$	3.8	3.9	4.1	V
$V_{UVLOHYS}$	Undervoltage detection hysteresis		50	100	200	mV
V_{OVP}	Overvoltage protection voltage		6.0	6.2	6.4	V
		PSI5	22	24	26	V
$V_{OVPHYST}$	Overvoltage detection hysteresis		50		200	mV
		PSI5	0.8	1.4	2.0	V
I_{short}	Output short-circuit current	Shorted to ground, analog output	-	-	15	mA
		Shorted to ground, PWM, SENT push-pull outputs	-	-	30	mA
		Shorted to power, analog output	-	-	15	mA
		Short-Circuit to power, PWM, SENT push-pull outputs	-	-	30	mA
R_L	Analog output load resistance	Pull-up resistor, connected to power supply	4.7	10	-	k Ω
		Pull-down resistor, connected to ground	4.7	10	-	k Ω
R_{L_PWM}	PWM output load resistance	Pull-up resistor, connected to power supply	1	-	-	k Ω
		Pull-down resistor, connected to ground	1	-	-	k Ω

Electrical Characteristics (Continued)

V _{sat_lo}	Analog output saturation level	Pull-up resistor R _≥ 10k, connected to power supply	-	0.5	2	%V _{DD}
		Pull-up resistor R _≥ 4.7k, connected to power supply	-	2.5	3	%V _{DD}
V _{sat_hi}		Pull-down resistor R _≥ 4.7k, connected to ground	95	98	-	%V _{DD}
		Pull-down resistor R _≥ 10k, connected to ground	97	99	-	%V _{DD}
V _{satD_lo}	Digital output level	Pull-up resistor R _≥ 10k, connected to the power supply	-	0.5	1	%V _{DD}
		Pull-up resistor R _≥ 1k, connected to the power supply	-	2.5	4	%V _{DD}
V _{satD_hi}		Pull-down resistor R _≥ 1k, connected to ground	85	90	-	%V _{DD}
		Pull-down resistor R _≥ 10k, connected to ground	97.5	98	-	%V _{DD}
D _{sat_lo}	Active diagnostic output level	Pull-up resistor R _≥ 10k	-	0.5	1	%V _{DD}
		Pull-up resistor R _≥ 4.7k	-	1	2	%V _{DD}
D _{sat_hi}		Pull-down resistor R _≥ 10k	97.5	98.5	-	%V _{DD}
		Pull-down resistor R _≥ 4.7k	95	97	-	%V _{DD}
BV _{SS} PD	Passive diagnostic output level (Open drain)	V _{SS} Open, pull-down resistor, R _≤ 10k	-	0.5	1.6	%V _{DD}
BV _{SS} PU		V _{SS} Open, pull-up resistor, R _≥ 1k, pull-up to 5V	99.5	100	-	%V _{DD}
BV _{DD} PD		V _{DD} Open, pull-down resistor, R _≥ 1k	-	0	0.5	%V _{DD}
BV _{DD} PU		V _{DD} Open, pull-up resistor, R _≤ 10k, pull-up to 5V	97	99.5	-	%V _{DD}
Clamp_lo	Programmable clamp voltage	Programmable	0	-	100	%V _{DD}
Clamp_hi		Programmable	0	-	100	%V _{DD}

Note:

(1)Based on the description in the table above, the SC69411 can meet the output range settings for the typical application of Fig.6

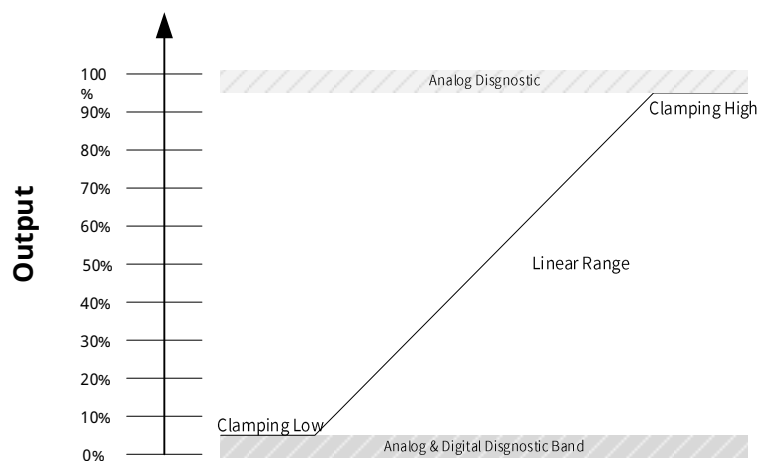

Fig.6 Example of Output Range for Typical Application

Timing parameters - basic timing

Symbol	Parameters	Test Conditions	Min.	Typ.	Max.	Units
F_{CK}	Master Clock Frequency	Full Temperature Test	7.8	8.2	8.5	MHz
$\Delta F_{CK,T}$	Main Clock Frequency Temperature Offset		-3	-	3	% F_{CK}
T_{per}	Data Refresh Frequency		121	128	134	μs
T_s	Step Response Time		-	128	-	μs
T_{POR}	Power-On Reset		-	40	-	μs
T_{INIT}	Initialization Time		-	3	5	ms
SR	Simulated output conversion rate	$C_{OUT}=10nF$	-	80	-	V/ms
		$C_{OUT}=47nF$	-	85	-	V/ms
		$C_{OUT}=100nF$	-	60	-	V/ms
		$C_{OUT}=330nF$	-	20	-	V/ms

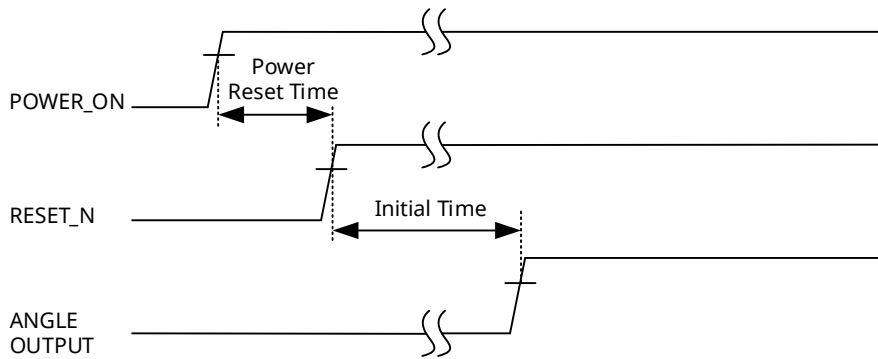

Fig.7 Power-on reset timing sequence

Timing parameters - EEPROM Timing

Symbol	Parameters	Test Conditions	Min.	Typ.	Max.	Units
t_{ps}	Power-on Reset Time		-	100	-	μs
t_{pw}			-	100	-	μs
TIDLE	Standby Time		-	20	-	ms

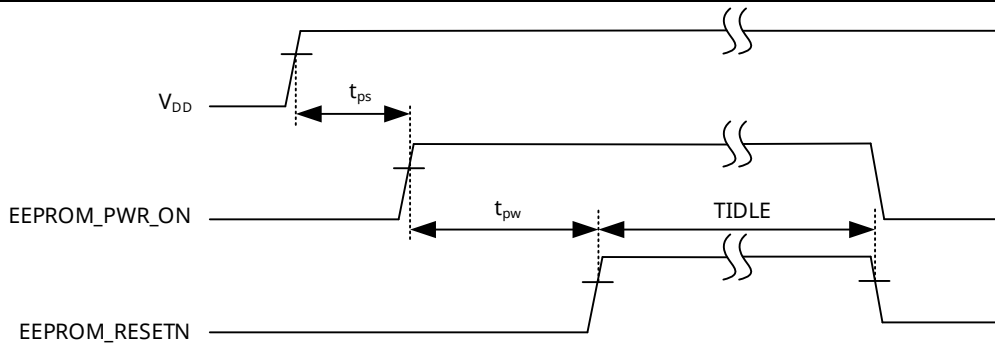

Fig.8 EEPROM Timing

Timing parameters - PWM Output

Symbol	Parameters	Test Conditions	Min.	Typ.	Max.	Units
F_{PWM}	PWM Frequency	Frequency range	100	-	2000	Hz
F_{PWM_Init}	PWM Frequency Initial Tolerances	25°C	-	-	±2%	F_{PWM}
		25°C	-	-	±1%	F_{PWM}
ΔF_{PWM}	PWM Frequency Temperature Drift	PWM frequency temperature drift	-	-	±3%	F_{PWM}
T_{rise_LSD}	PWM Output Rise Time (Open-Drain Output)	4.7nF, $R_L=1k\Omega$ pull-up	-	10	-	μs
		10nF, $R_L=1k\Omega$ pull-up	-	20	-	μs
T_{rise_PP}	PWM Output Rise Time (Push-Pull Output)	4.7nF, $R_L=1k\Omega$ pull-up	-	3	-	μs
		10nF, $R_L=1k\Omega$ pull-up	-	4	-	μs
T_{fall_LSD}	PWM Output Fall Time (Open-Drain Output)	4.7nF, $R_L=1k\Omega$ pull-up	-	2	-	μs
		10nF, $R_L=1k\Omega$ pull-up	-	4	-	μs
T_{fall_PP}	PWM Output Fall Time (Push-Pull Output)	4.7nF, $R_L=1k\Omega$ pull-up	-	2	-	μs
		10nF, $R_L=1k\Omega$ pull-up	-	4	-	μs

Timing parameters - SENT Output

Symbol	Parameters	Test Conditions	Min.	Typ.	Max.	Units
$TICK_{time}$	Tick Time		1.5	-	6	μs
N_{nibble}	Number of data Nibble		3	6	-	-
T_{rise}	SENT edge rise time	Between 1.1V and 3.8V	-	12.5	18	μs
T_{fall}	SENT edge fall time	Between 1.1V and 3.8V	-	5.3	6.5	μs
N_{pp}	SENT frame cycle (no pause bit)		154	-	270	ticks
P_{pc}	SENT frame cycle (with pause bit)		282	-	922	ticks
A.1	Sensor type	Dual Body Position Sensor	-	-	-	-
A.3		Single Reliable Sensor	-	-	-	-
T_{FRAME}	SENT frame cycle (slow)	Standard data sequence (40 frames)	-	691	-	ms
		Extended Data Sequence (24 frames)	-	415	-	ms

Timing parameters - PS15 Output

Symbol	Parameters	Test Conditions	Min.	Typ.	Max.	Units
T _{cycle}	Communication cycle			300		μs
				500		μs
				1000		μs
T _{bit}	bit time	125 kbit/s	7.6	8	8.4	μs
		189 kbit/s	5	5.3	6	μs
T _{SHOLD}	Synchronization pulse hold time		9			μs
T _{RISE}	Current slope rise time		0.33		1	μs
TFALL	Current slope fall time		0.33		1	μs
MSR	Mark/Space Ratio	$(t_{fall, 80} - t_{rise, 20}) / T_{Bit}, (t_{fall, 20} - t_{rise, 80}) / T_{Bit}$	47	50	53	%

Accuracy Parameters - Analog Output

Symbol	Parameters	Test Conditions	Min.	Typ.	Max.	Units
R _{ADC}	ADC resolution		-	15	-	bits
R _{DAC}	Analog output resolution		-	12	-	bits
INL	DAC integral nonlinearity error		-	5	-	LSB
DNL	DAC differential nonlinearity error		0.05	1	3	LSB
ΔE _{ang}	Angle offset error		-1	-	1	Deg
ΔE _L	Non-linearity error		-1	-	1	Deg
ΔE _{temp}	Angular temperature drift error		-0.5	-	0.5	Deg
ΔE _{ratio}	Proportion output error	4.5V ≤ V _{DD} ≤ 5.5V	-0.05	0	0.5	%V _{DD}
N _{pk-pk}	Output noise		-	0.05	0.2	Deg

Accuracy Parameters - PWM Output

Symbol	Parameters	Test Conditions	Min.	Typ.	Max.	Units
RSP	PWM Output Resolution		-	12	-	bits
J _{DC}	PWM % Duty Cycle Jitter (Open-Drain Output)	125Hz,4.7nF, R _L =1kΩ, Resistor Pull-Up	-	±0.003	±0.016	%DC
		250Hz,4.7nF, R _L =1kΩ, Resistor Pull-Up	-	±0.005	±0.02	%DC
		500Hz,4.7nF, R _L =1kΩ,Resistor Pull-Up	-	±0.009	±0.035	%DC
		1000Hz,4.7nF, R _L =1kΩ,Resistor Pull-Up	-	±0.003	±0.016	%DC
		2000Hz,4.7nF, R _L =1kΩ,Resistor Pull-Up	-	±0.005	±0.02	%DC
J _{DC}	PWM % Duty Cycle Jitter (Push-Pull Output)	125Hz,4.7nF, R _L =1kΩ, Resistor Pull-Up	-	±0.003	±0.016	%DC
		250Hz,4.7nF, R _L =1kΩ, Resistor Pull-Up	-	±0.005	±0.02	%DC
		500Hz,4.7nF, R _L =1kΩ, Resistor Pull-Up	-	±0.009	±0.035	%DC
		1000Hz,4.7nF, R _L =1kΩ,Resistor Pull-Up	-	±0.003	±0.016	%DC
		2000Hz,4.7nF, R _L =1kΩ,Resistor Pull-Up	-	±0.005	±0.02	%DC
J _{PWM}	PWM Frequency Jitter (Open-Drain Output)	125Hz-2000Hz,4.7nF, R _L =1kΩ,Resistor Pull-Up	-	±0.04	±0.15	Hz
J _{PWM}	PWM Frequency Jitter (Push-Pull Output)	125Hz-2000Hz,4.7nF, R _L =1kΩ,Resistor Pull-Up	-	±0.04	±0.15	Hz

Magnetic parameter

Symbol	Parameters	Test Conditions	Min.	Typ.	Max.	Units
H _{EXT}	Magnetic field strength		10	-	120	mT
D _{mag}	Magnet diameter		-	6	-	mm
H _{mag}	Magnet thickness		-	2.5	-	mm
AG	Magnet To Chip Gap		0.5	-	3	mm
	Magnetic material		-	NdFeB 35	-	-

9. Block Diagram

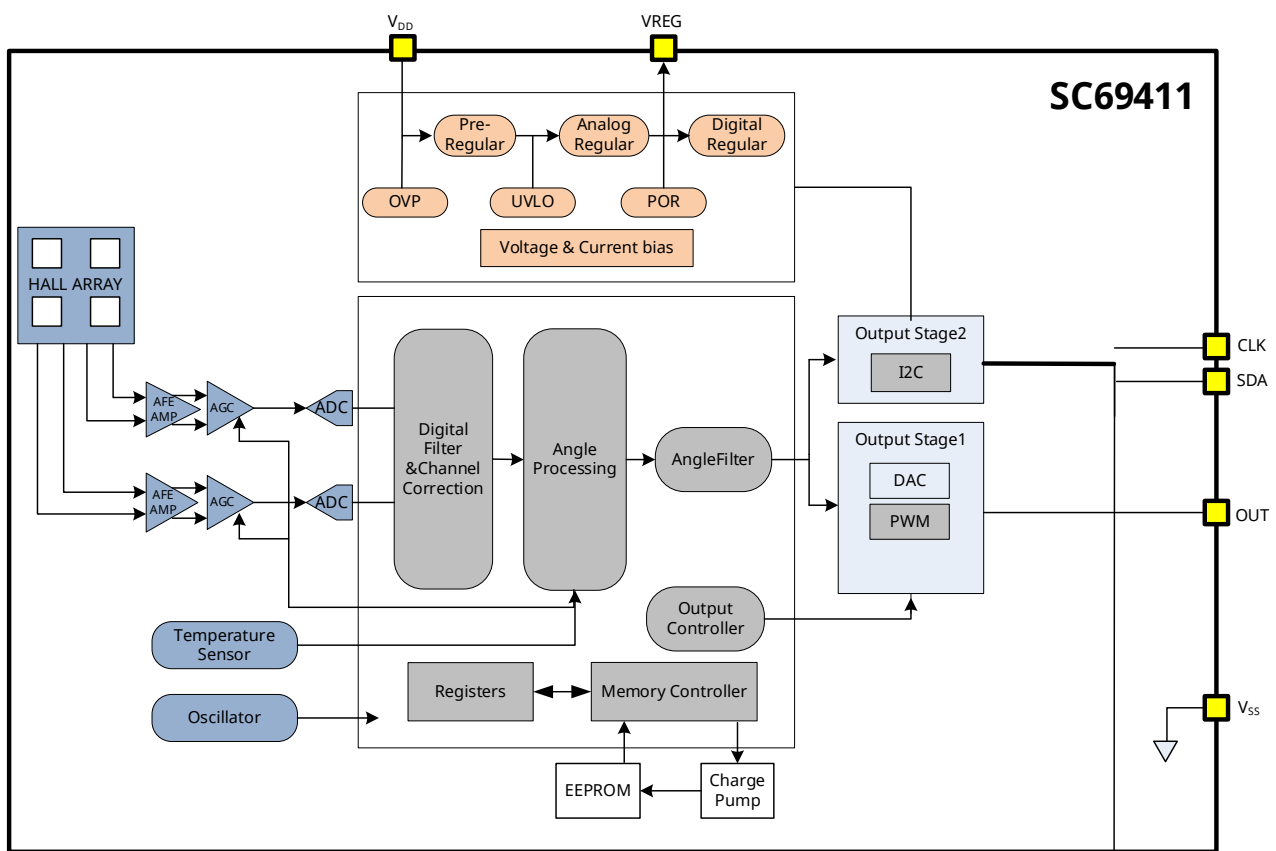

Fig.9 Functional block diagram

10. Function Description

User programmable parameters

Parameters	Description	Default	Bits
General Parameter Settings			
Filter	Filter selection	2	2
OUT_mode	Output mode	0	3
PWM_POL	PWM polarity	0	1
PWMT	PWM frequency	0	16
OUT_CONFIG	PWM, SENT output configuration	0	2
GAIN_G	Simulation of operational amplifier first-stage gain setting	0	2
AGC	Automatic Gain Control (AGC) for the 2nd stage of the analog op-amp	1	1
GAIN_F	Gain setting for the 2nd stage of the analog op-amp	1	5
USER_ID1	User ID	0	8
USER_ID2	User ID	0	8
USER_ID3	User ID	0	8
USER_ID4	User ID	0	8
EEPROM_LOCK_CODE	EEPROM lock code / EEPROM lock key	0	8
SENT configuration parameters			
SENT_FC_FORMAT	SENT frame data format selection	1	1
SENT_CH2_DATA	Channel 2 data configuration	2	2
SENT_INIT_DATA	SENT startup initialization data configuration	0	1
SENT_NIBBLE_NUMBER	Channel 2 data nibble count selection	1	1
SENT_TICK_TIME	SENT tick time configuration	0	3
SENT_LEGACY_CRC	CRC calculation options	0	1
SENT_SERIAL_CONFIG	Enhanced serial message selection	1	1
SENT_SLOW_EXTENDED	Serial message sequence selection	0	1
SENT_SLOW_BFIELD	Serial message extension sequence magnetic field configuration	1	1
SENT_PAUSE_OPTION	Selection of the measurement mode and the corresponding output protocol	1	1
SENT_REV	SENT version	4	3
SENT_MAN_CODE	factory code	0	12
SENT_FRAME_LENGTH	frame length	297	10

User programmable parameters(Continued)

SENT_SERIALERROR	Report diagnostics via fast channel	0	3
SENT_SENSOR_TYPE	Sensor type	0x05	8
SENT_CHANNEL_X1	CHANNEL X1	0	12
SENT_CHANNEL_X2	CHANNEL X2	0	12
SENT_CHANNEL_Y1	CHANNEL Y1	0	12
SENT_CHANNEL_Y2	CHANNEL Y2	0	12
SENT_SENSOR_ID1	Sensor ID1	0	12
SENT_SENSOR_ID2	Sensor ID2	0	12
SENT_SENSOR_ID3	Sensor ID3	0	12
SENT_SENSOR_ID4	Sensor ID4	0	12
SENT_OEM_CODE1	OEM code 1	0	12
SENT_OEM_CODE2	OEM code 2	0	12
SENT_OEM_CODE3	OEM code 3	0	12
SENT_OEM_CODE4	OEM code 4	0	12
SENT_OEM_CODE5	OEM code 5	0	12
SENT_OEM_CODE6	OEM code 6	0	12
SENT_OEM_CODE7	OEM code 7	0	12
SENT_OEM_CODE8	OEM code 8	0	12
PSI5 configuration parameters			
PSI5_OUT_MODE	PSI5 Output Mode	3	2
PSI5_PAYLOAD_SIZE	Effective data length	20	5
PSI5_ERROR_DETECTION	Error Detection Methods	0	1
PSI5_CYCLE_TIME	communications cycle	0	2
PSI5_TRANSMIT_SPEED	data transfer speed	1	1
PSI5_FORMAT_PRECISION	Data frame format accuracy	1	1
PSI5_TRIGGER_LEVEL	Synchronized pulse trigger level setting	1	1
PSI5_TS[1..4]_ENABLE	Timeslot Enable	0	1
PSI5_TS[1..4]_SENSOR	Transmitted time slot data selection	3	3
PSI5_TS[1..4]_STARTTIME	time slot start time	0	11
PSI5_INIT_PHASES	Initialization Configuration	0	2
PSI5_INIT_I_DURATION	Initialization 1 phase cycle	100	8

User programmable parameters(Continued)

PSI5_INIT_II_EXTRA_FIELDS	Initialization 2 Stage Extended Data Enable	0	1
PSI5_INIT_II_REPETITION	Initialization 2-stage repetition count	1	2
PSI5_INIT_METAINFO	PSI5 version	6	4
PSI5_INIT_INITLENGTH	Initialization 2-stage data length	9	8
PSI5_INIT_VENDORID	Supplier ID	6	8
PSI5_INIT_SENSORTYPE	Sensor type	6	4
PSI5_INIT_SENSORPARAMS	Sensor specified parameters	0	8
PSI5_INIT_SENSORCODE	Sensor Manufacturer Specified Parameters	0	8
PSI5_INIT_SENSORAPPCODE	Product version information	0	12
PSI5_INIT_PRODUCTIONDATE	date of manufacture	0	16
Diagnostic Function Setting			
DIAG_EN	Diagnostic Enable Bit	1	1
DIAG_MASK	Diagnostic Mask Register	128	8
DC_FAULT	Output duty cycle of PWM when supply voltage is too low	0	8
DC_FTL	Output duty cycle of PWM when magnetic field is too low	0	8
GAIN_THRESHOLD_LOW	Analog op amp second stage gain low thresholds	0	5
GAIN_THRESHOLD_HIGH	Analog op amp second stage gain high thresholds	31	5
FIELDHOLD_LOW	low field strength threshold	0	8
FIELDHOLD_HIGH	High field strength threshold	255	8
TEMPHRESHOLD_LOW	low-temperature threshold	0	7
TEMPHRESHOLD_HIGH	High-temperature threshold	127	7
DIAG_DEBOUNCE	Diagnostic de-jittering time	0	3
Linear Transfer Curve Setting Parameters			
OUTSLOPE_COLD	Low-temperature angle compensation coefficient	0	8
OUTSLOPE_HOT	High-temperature angle compensation coefficient	0	8
CLAMP_HIGH	Output high clamp	65535	16
CLAMP_LOW	Output low clamp	0	16
DP	Breakpoint / Zero point	0	16
CW	Rotation direction	0	1
WORK_RANGE_GAIN	16-point / 32-point calibration working angle range (deg)	360	16
LNR_POINTS	Calibration point selection	3	2

User programmable parameters(Continued)

LNR_A_X	4-point calibration , X-axis coordinates (angle)	0	16
LNR_B_X		0	16
LNR_C_X		0	16
LNR_D_X		0	16
LNR_A_Y	4-point calibration, Y-axis coordinates (%VDD)	0	16
LNR_B_Y		0	16
LNR_C_Y		0	16
LNR_D_Y		0	16
LNR_A_S	4-point calibration, slope of each segment	0	16
LNR_B_S		0	16
LNR_C_S		0	16
LNR_D_S		0	16
LNR4_S0	4-point calibration, initial slope	0	16
LNR4_Y5	4-point calibration, endpoint Y coordinate	0	16
LNR_Y0	4-point, 16-point/32-point calibration of initial point Y-coordinate	0	16
LNR9_Yn	8-point calibration, Y-axis coordinates (n=0~8)	0	9x16
LNR9_Xn	8-point calibration, X-axis coordinates (n=0~8)	0	9x16
LNR17_Yn	16-point calibration, Y-axis coordinates (n=0~15)	0	17x16
LNR_DELTA_Yn	32-point calibration, Y-axis coordinates (offset %) (n=0~31)	0	32x8
LNR_DELTA_Y_EXPAND	32-point calibration, Y-axis coordinate deviation range setting	3	2

Output Modes

SC69411 supports five output modes: ratiometric analog output, PWM output, SENT output, I²C output and PSIS output. PWM and SENT support both open-drain and push-pull output configurations.

Parameters	Value	Description
OUT mode [2:0] +	0	I ² C output
	1	Analog output
	2	SENT
	3	PWM
	4	PSIS
	5	I ² C output
	6	I ² C output
	7	I ² C output

PWM Output Mode - Output Polarity Setting

Parameters	Value	Description
PWM POL	0	Active low
	1	Active high

PWM Output Mode - Output frequency Setting

Parameters	Value	Description
PWMT [15:0]	2000 40000	100-2000Hz frequency

PWM Output Mode – SENT Setting

Parameters	Value	Description
OUT_CONFIG [1:0]	0	Digital high-impedance output
	1	Digital output NMOS Open Drain
	2	Digital output PMOS Open Drain
	3	Digital push-pull output

PWM Output Mode – output waveform

PWM is set to PWM_POL=0, PWMT=0x0FA0 (1000Hz), and the PWM output waveform when the output duty cycle is 0.0244%.

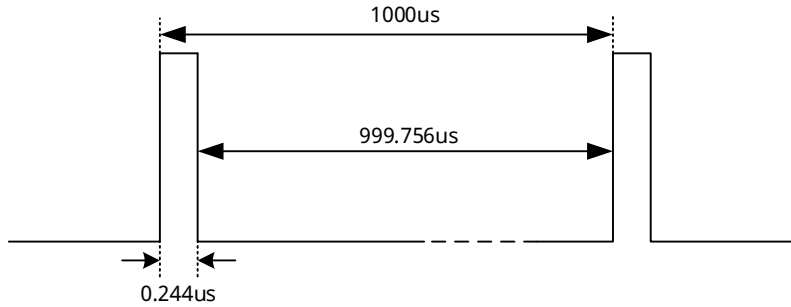

Fig.10 PWM output waveform when PWM_POL=0

PWM is set to PWM_POL=1, PWMT=0x0FA0 (1000Hz), and the PWM output waveform when the output duty cycle is 0.0244%.

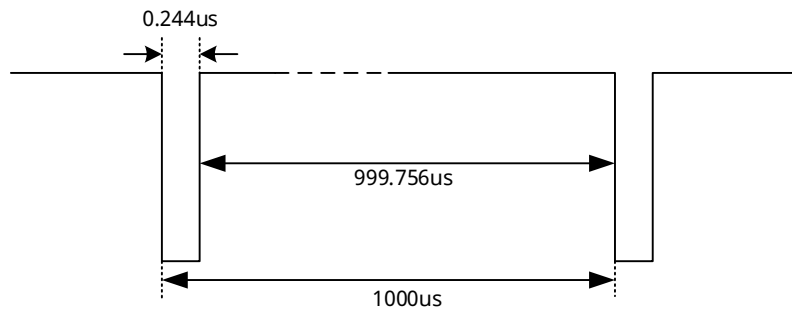

Fig.11 PWM output waveform when PWM_POL=1

SENT protocol output

The digital SENT output of SC69411 is compatible with SAE J2716 APR2016.

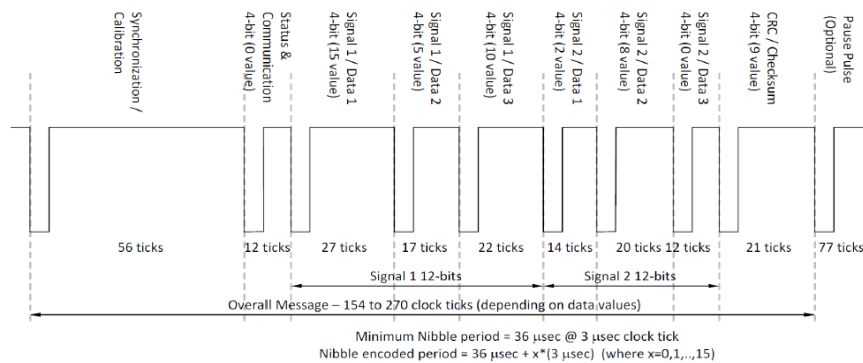

Fig.12 Example of 2-channel 12-bit data SENT information format

SENT Protocol Output - Selection of SENT Fast Frame Data Format

Parameters	Value	Description
SENT_FC_FORMAT [0]	0	Dual Throttle Position Sensor
	1	Single safety position sensors

SENT Protocol Output - A.1 Dual Valve Body Position Sensor Data Frame

SC69411 sends a string of data bytes according to the dual valve body position sensor defined in Appendix A.1 of SAE J2716. CH1 continuously sends 12-bit sensor data, and the content of CH2 channel is set by SENT CH2 DATA.

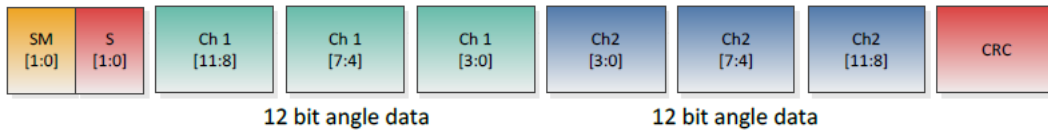

Fig.13 A.1 Dual Valve Body Position Sensor Data Frame

SENT Protocol Output - Channel 2 Configuration for Number of Nibbles

Parameters	Value	Description
SENT_NIBBLE_NUMBER [0]	0	3 nibbles
	1	6 nibbles

SENT Protocol Output - Channel 2 Configuration Data

Parameters	Value	Description
SENT CH2 DATA [1:0]	0	12-bit temperature sensor data
	1	0xFF9(4089)-CH1
	2	User-defined 12-bit data
	3	0xFFF(4095)-CH1

SENT Protocol Output - A.3 Single Reliable Position Sensor Data Frame

SC69411 transmits 12-bit sensor angle data of CH1 channel, roll counter, and the inverted data of the high 4 bits of angle data according to the single safety position sensor defined in Appendix A.3 of SAE J2716.



Fig.14 A.3 Single Reliable Position Sensor Data Frame

SENT Protocol Output - Initialization Start Frame

Parameters	Value	Description
SENT INIT DATA 【1:0】	0	OEM Requirements - 0xFF
	1	SAE Compatible-0x00

SENT Protocol Output - SENT tick Time Configuration

Parameters	Value	Description
OUT mode 【2:0】	0	3.0us Standard SENT
	1	Reserved
	2	Reserved
	3	1.5us Fast SENT
	4	Reserved
	5	Reserved
	6	6.0us Slow SENT
	7	Reserved

SENT Protocol Output - Frame Length Setting

Parameters	Value	Description
SENT_FRAME_LENGTH 【9:0】	Default 297 ticks	Frame length setting

SENT Protocol Output - SENT Version Selection

Parameters	Value	Description
SENT_REV 【2:0】	0	没有指定版本
	1	2007
	2	2008
	3	2010
	4	2016

SENT Protocol Output - Enhanced Serial Message

The enhanced serial message is a communication protocol that can transmit a large amount of data and information IDs. Serial data is transmitted through the 2nd and 3rd bits SM[1:0] of the status and communication Nibble. As shown in the figure, a serial information frame consists of 18 consecutive SENT data information, and all 18 frames must be successfully received (without errors such as calibration pulse changes, data byte CRC errors, etc.).

The enhanced serial message includes an enhanced serial information with 12 - bit data and 8 - bit information ID. SM[0] contains 6 - bit CRC, followed by 12 - bit data. The information content is defined by the 8 - bit information ID transmitted in the SM[1] channel. By default, a short sequence consisting of 24 data is transmitted. An extended sequence can be optionally used to transmit a cycle containing 40 data.

In addition, at the end of the sequence (short sequence or extended sequence), the standard value of the magnetic field detected by the sensor can be optionally returned.

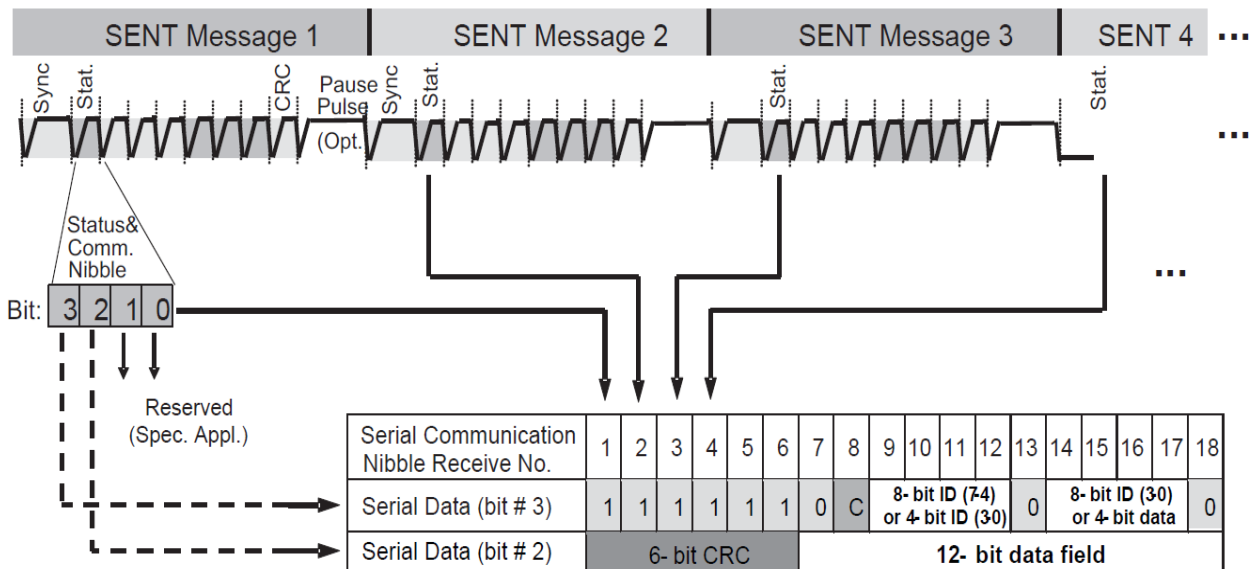

Fig.15 Enhanced Serial Message Data Format

Num	8-Bit Id	Element	Description
Standard sequence			
1	0x01	Diagnostic error code	Diagnostic register
2	0x06	SENT standard revision	SENT_REV
3	0x01	Diagnostic error code	Diagnostic register
4	0x05	Manufacturer code	SENT_MAN_CODE
5	0x01	Diagnostic error code	Diagnostic register
6	0x03	Channel 1 / 2 Sensor type	SENT_SENSOR_TYPE
7	0x01	Diagnostic error code	Diagnostic register
8	0x07	Fast channel 1: X1	SENT_CHANNEL_X1
9	0x01	Diagnostic error code	Diagnostic register
10	0x08	Fast channel 1: X2	SENT_CHANNEL_X2
11	0x01	Diagnostic error code	Diagnostic register
12	0x09	Fast channel 1: Y1	SENT_CHANNEL_Y1
13	0x01	Diagnostic error code	Diagnostic register
14	0x0A	Fast channel 1: Y2	SENT_CHANNEL_Y2
15	0x01	Diagnostic error code	Diagnostic register
16	0x23	(Internal) temperature	Temperature register
17	0x01	Diagnostic error code	Diagnostic register
18	0x29	Sensor ID #1	SENT_SENSOR_ID1
19	0x01	Diagnostic error code	Diagnostic register
20	0x2A	Sensor ID #2	SENT_SENSOR_ID2
21	0x01	Diagnostic error code	Diagnostic register
22	0x2B	Sensor ID #3	SENT_SENSOR_ID3
23	0x01	Diagnostic error code	Diagnostic register
24	0x2C	Sensor ID #4	SENT_SENSOR_ID4
Extended sequence			
25	0x01	Diagnostic error code	Diagnostic register
26	0x90	OEM Code #1	SENT_OEM_CODE1
27	0x01	Diagnostic error code	Diagnostic register
28	0x91	OEM Code #2	SENT_OEM_CODE2
29	0x01	Diagnostic error code	Diagnostic register
30	0x92	OEM Code #3	SENT_OEM_CODE3
31	0x01	Diagnostic error code	Diagnostic register

Num	8-Bit Id	Element	Description
32	0x93	OEM Code #4	SENT_OEM_CODE4
33	0x01	Diagnostic error code	Diagnostic register
34	0x94	OEM Code #5	SENT_OEM_CODE5
35	0x01	Diagnostic error code	Diagnostic register
36	0x95	OEM Code #6	SENT_OEM_CODE6
37	0x01	Diagnostic error code	Diagnostic register
38	0x96	OEM Code #7	SENT_OEM_CODE7
39	0x01	Diagnostic error code	Diagnostic register
40	0x97	OEM Code #8	SENT_OEM_CODE8
Magnetic field expansion			
41	0x80	Field Strength	Magnetic Field Strength Register (Extended Sequence)

Note:

(1) $SENT@ ID 23 = 8 * (T[C] - 35[C]) + 865 LSB12$

SENT Protocol Output - Enhanced Serial Message Slow Channel Selection

Parameters	Value	Description
SERIAL_CONFIG 【0】	0	Disable Enhanced Serial Messaging Slow Channel
	1	Enable Enhanced Serial Message Slow Channel

SENT Protocol Output - Enhanced Serial Message Sequence Selection

Parameters	Value	Description
SENT_SLOW_EXTENDED 【0】	0	Short-sequence serial message selection
	1	Extended Sequence Serial Message Selection

SENT Protocol Output - When the extended sequence is enabled, you can configure whether to use magnetic field extension

Parameters	Value	Description
SENT_SLOW_BFIELD 【0】	0	No magnetic field expansion
	1	With magnetic field expansion

SENT Protocol Output - PAUSE Configuration

Parameters	Value	Description
SENT_PAUSE_OPTION 【0】	0	Continuous asynchronous angle acquisition, no pause bit in SENT
	1	Continuous synchronized angle acquisition, SENT with pause bit

PSI5 Protocol Output

According to the PSI5 protocol specification, information is transmitted by modulating the current of the power supply pin VDD. SC69411 complies with PSI5 protocol specification v2.3 and is backward compatible with v2.1 and v1.3.

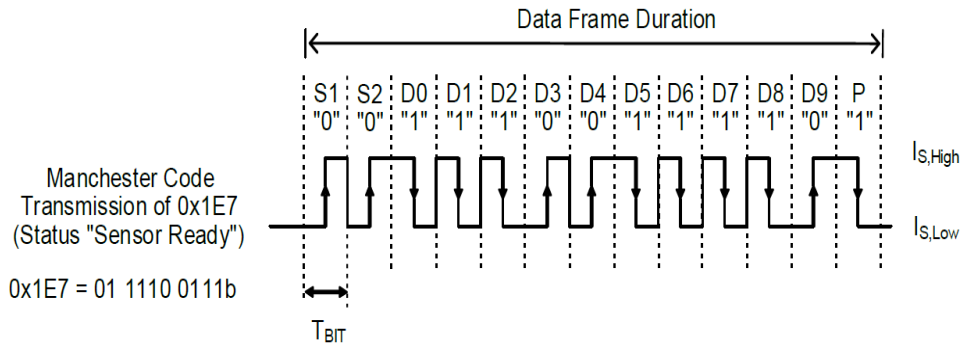

Fig.16 PSI5 Manchester Encoding Format

PSI5 Protocol Output - Data Frame Format

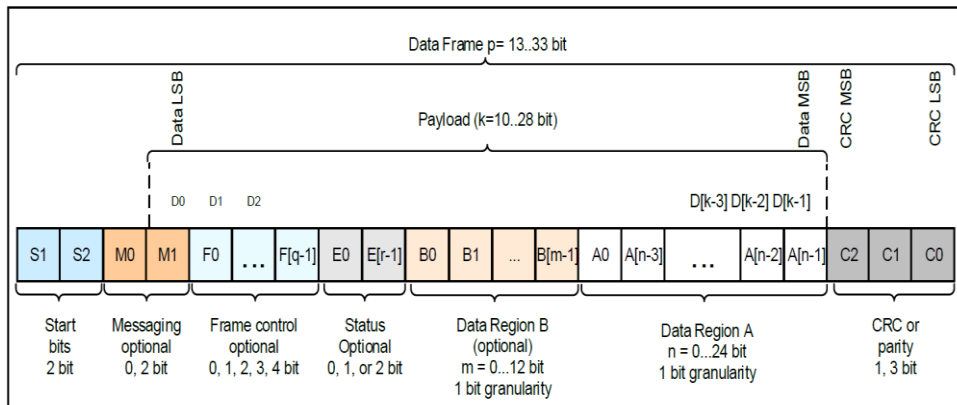

Fig.17 PSI5 Data Frame Format

PSI5 Protocol Output - Error Detection Method

Parameters	Value	Description
PSI5_ERROR_DETECTION 【1:0】	0	CRC mode
	1	Parity check

PSI5 Protocol Output - Data Length

Parameters	Value	Description
PSI5_PAYLOAD_SIZE 【4:0】	8-24	Data length
PSI5_FORMAT_PRECISION 【0】	0	Low precision
	1	Highly accurate

Parameters	Value	Description
PSI5_FORMAT_PRECEISION 【0】	0	Closing time slots
	1	Enable time slots
PSI5_TSx_SENSOR 【2:0】	0	Angular data
	1	-
	2	Temp
	3	Magnetic fields
	4	-
PSI5_TS[1..4]_STARTTIME 【10:0】	11	Time slot start time

PSI5 Protocol Output - PSI5 Current Modulation Method

Data frames are transmitted through a current consumption modulator, and the encoding method is Manchester encoding. The low level ($I_{S,Low}$) represents the static current consumption of the sensor, and the high level ($I_{S,High}$) is generated by the increase of the sensor's sink current ($I_{S,Low} + \Delta I_S$). The high level ($I_{S,High}$) is generated by ($I_{S,Low} + \Delta I_S$). The sink current (ΔI_S) and bit duration (T_{BIT}) can be selected.

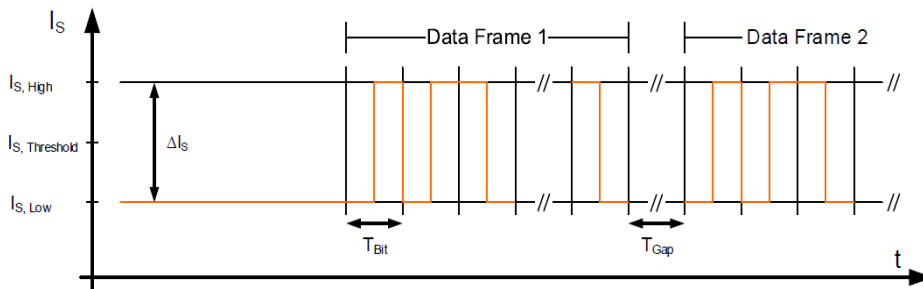

Fig.18 PSI5 data current modulation

Parameters	Value	Description
PSI5_LOWCOMMON_MODE 【1:0】	0	Low current 13mA
	1	Normal current 26 mA

PSI5 Communication Mode

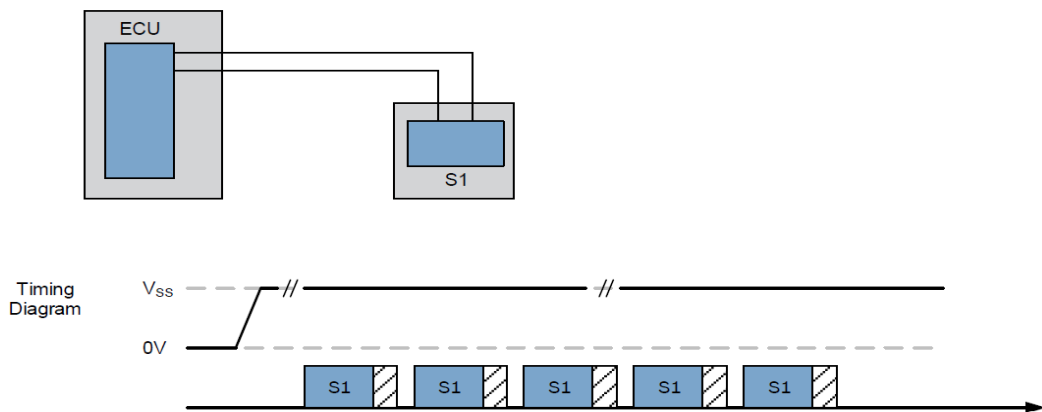

Fig.19 PSI5 Asynchronous mode

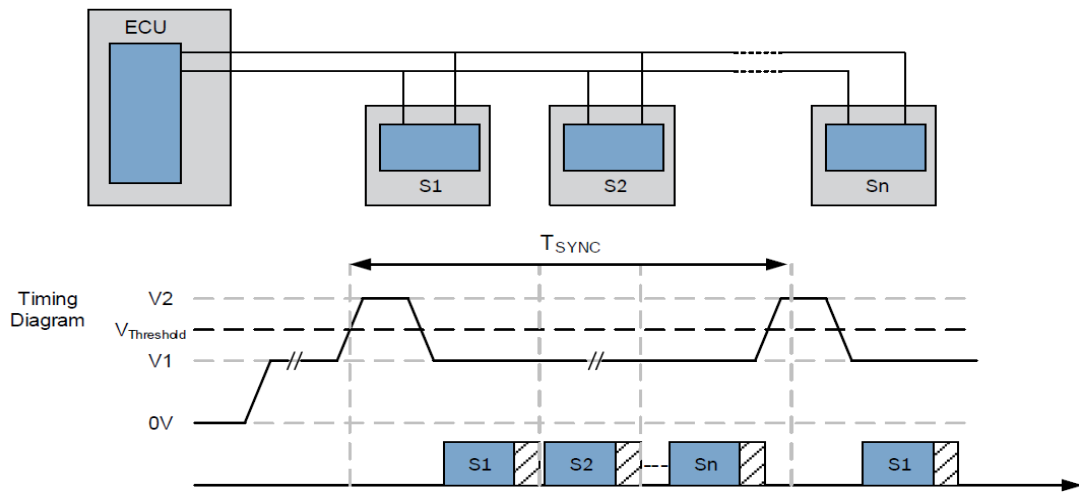

Fig.20 PSI5 Synchronous parallelism

PSI5 Protocol Output - Output Mode

Parameters	Value	Description
PSI5_OUT_MODE 【1:0】	2	Asynchronous mode
	3	Synchronous parallelism

PSI5 Protocol Output - Cycle Time

Parameters	Value	Description
PSI5_OUT_MODE 【1:0】	0	300μs
	1	500μs
	2	1000μs

PSI5 Protocol Output - Transmission Speed

Parameters	Value	Description
PSI5_TRANSMIT_SPEED	0	Low speed 125 kbit/s
	1	High speed 189kbit/s

PSI5 Protocol Output - Setting of Synchronous Pulse Trigger Time

Parameters	Value	Description
PSI5_TRIGGER_LEVEL 【0】	0	Reduced synchronization pulses
	1	Standard Synchronized Pulse

PSI5 Protocol Output - Sensor Initialization

Initialization Phase 1	Initialization Phase 2	Initialization Phase 3	Operating Mode
Activate (a plan)	Data content	State of affairs	Sensor or status data

PSI5 Protocol Output - Initialization Function Configuration

Parameters	Value	Description
PSI5_INIT_PHASES 【1:0】	0	Normal initialization
	1	Close initialization phase 2
	2	Close initialization phases 2 and 3
	3	Reserved

PSI5 Protocol Output - Initialization Phase 1 Cycle

Parameters	Value	Description
PSI5_INIT_I_DURATION 【7:0】	100	50-200ms

PSI5 Protocol Output - Data content

Parameters	Data field	Value	Description
Forced data			
1	F1(D1)	PSI5_INIT_METAINFO	PSI5 version
2	F2(D2, D3)	PSI5_INIT_INITLENGTH	Initialize data length
3	F3(D4, D5)	PSI5_INIT_VENDORID	Supplier ID
4	F4(D6, D7)	PSI5_INIT_SENSORTYPE	Sensor type
5	F5(D8, D9)	SI5_INIT_SENSORPARAMS	Sensor specified parameters
Extended data			
6	F6(D10, D11)	PSI5_INIT_SENSORCODE	Parameters specified by the sensor manufacturer
7	F7(D12-D14)	PSI5_INIT_SENSORAPPCODE	Product version information
8	F8(D15-D18)	PSI5_INIT_PRODUCTION DATE	production date
9	F9(D19-D22)	SEMI_ID	SEMI_ID

PSI5 Protocol Output - Initialization Phase 3

Parameters	Value	Description
"Sensor ready"	0x1E7	status data
"Sensor defect"	0x1F4	status data

Two-wire I2C protocol output (slave device)

Sensor front-end setup

First-level gain setting

Parameters	Value	Description
GAIN_G 【2:0】	0	2.5
	1	5
	2	10
	3	15

Second-level gain setting

AGC enable is used to set the automatic gain control enable for the second-stage gain. When AGC is set to 1, the automatic gain control is enabled; when set to 0, the automatic gain control is disabled. If the AGC control bit is disabled, the second-stage gain is directly set through the register.

Parameters	Value	Description
AGC	0	Digital high-impedance output
	1	Enable automatic gain control
GAIN_F 【4:0】	0	1
	1	1.1
	2	1.21

	29	15.86
	30	17.4
	31	20

Traceable information

Each device includes a Saichuang factory ID and a user ID for traceability during factory shipment.

Parameters	Value
USER_ID1 【7:0】	0-255
USER_ID2 【7:0】	0-255
USER_ID3 【7:0】	0-255
USER_ID4 【7:0】	0-255

EEPROM Write Protection

Parameters	Value	Description
EEPROM_LOCK_CODE 【6:0】	0xAD	EEPROM read-only
	Other values	EEPROM can be read, written, and erased.

Diagnostic

Diagnostic Enable Parameters	Value	Description
DIAG_EN	0	Close Diagnostics
	1	Enable Diagnostics

Diagnostic Mask Register

Corresponding to mask position 0, the fault will not trigger diagnosis; corresponding to mask position 1, the fault will trigger diagnosis.

BIT7	BIT6	BIT5	BIT4	BIT3	BIT2	BIT1	BIT0
CRC Checksum Error	GAINF overflow	Current diagnosis	Digital Voltage Fault	CORDIC overflow	Fieldstreng thoverflow	ADC overflow	Temperature overflow

Analog Diagnostic Settings

Parameters	Value	Description
DIAG_MO 【1:0】	0	Digital High Resistance State Output
	1	Digital Output NMOS OpenDrain
	2	Digital Output PMOS OpenDrain
	3	Digital push-pull output

PWM Diagnostic Settings

Parameters	Value	Description
DC_FAULT 【7:0】	0-255	Output duty cycle of PWM when supply voltage is too low
DC_FTL 【7:0】	0-255	Output duty cycle of PWM when magnetic field is too low

Diagnostic Threshold

参数	数值	描述
GAIN_THRESHOLD_LOW 【4:0】	0-31	Low threshold of gain for the second-stage operational amplifier
GAIN_THRESHOLD_HIGH 【4:0】	0-31	High threshold of gain for the second-stage operational amplifier
TEMPTHRESHOLD_LOW 【6:0】	0-127	low temperature threshold
TEMPTHRESHOLD_HIGH 【6:0】	0-127	high temperature threshold
FIELDTHOLD_LOW 【7:0】	0-255	Low threshold of field strength
FIELDTHOLD_HIGH 【7:0】	0-255	High threshold of field strength

Diagnostic debounce time setting

Parameters	Value	STEP_UP TIME(ms)	STEP_DOWN TIME(ms)
DIAG_DEBOUNCE 【2:0】	0	20	20
	1	20	30
	2	20	40
	3	40	40
	4	60	80
	5	80	100
	6	100	120
	7	120	140

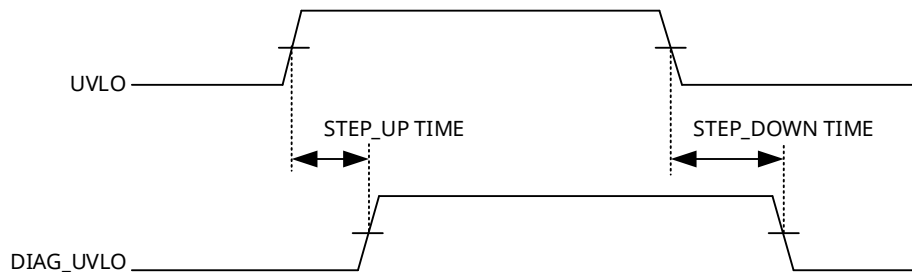

Fig.21 Diagnostic de-jittering timings

Output parameter settings

Angle output temperature compensation

The two parameters, OUTSLOPE_HOT and OUTSLOPE_COLD, are used to compensate for temperature-related offsets. This offset is applied to the angle before the clamping function. As shown in the following figure, the offset is calculated through the internal linearized temperature of the device.

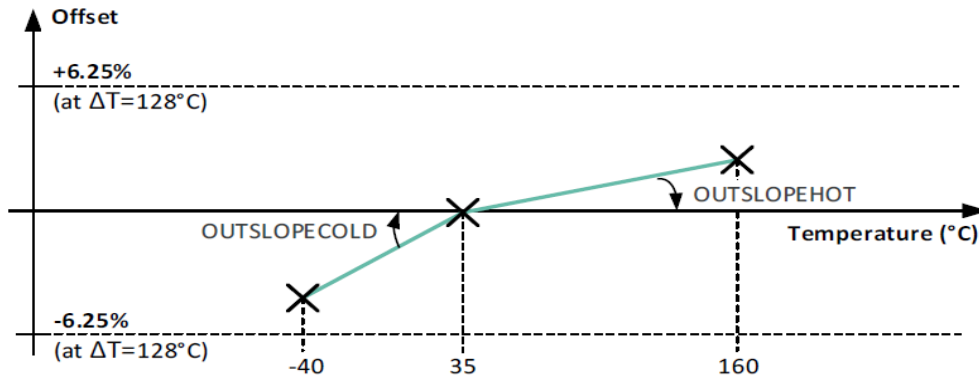

Fig.22 Temperature deviation map

The span of this offset is ±6.25% of the total output, and the linearized temperature depends on whether the temperature is below or above 35°C.

If the internal temperature of the chip is higher than 35°C: $Angle_{Compensated} = Angle - \Delta T * OUTSLOPE_HOT / 64$

If the internal temperature of the chip is lower than 35°C: $Angle_{Compensated} = Angle - \Delta T * OUTSLOPE_COLD / 64$

Output Clamp Setting

The output clamp setting is used to limit the output voltage range. CLAMP_LOW sets the output voltage minimum and CLAMP_HIGH sets the output voltage maximum. Both parameters work for 4-point, 8-point, 16-point, and 32-point correction modes.

Parameters	Value	Description
CLAMP_LOW	0-100%	Low clamping
CLAMP_HIGH	0-100%	High clamping

Breakpoint/Zero-DP

The breakpoint and zero point of SC69411 are the same point, which can be programmed at any point on the circumference. All angles are based on the breakpoint or zero point. DP is the transition point between 0 degrees and 360 degrees. For applications with a travel range less than 360 degrees, DP should not be set at the same position as the starting point of the working travel, but must be set outside the working travel.

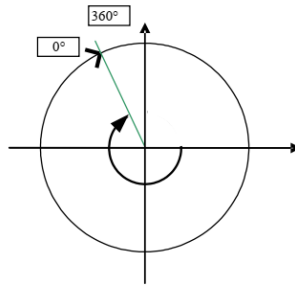

Fig.23 Schematic diagram of DP points

Parameters	Value	Description
DP	0-360	Breakpoint/Zero (degrees)

Direction of rotation

The CW parameter defines the direction of rotation of the magnet.

Counterclockwise is defined as rotation in 1-4-5-8 pin order (SOP8 package) or 1-8-9-16 pin order (eTSSOP16L package); clockwise is defined as the opposite direction, rotation in 8-5-4-1 pin order (SOP8 package) or 16-9-8-1 pin order (TSSOP16L package).

Parameters	Value	Description
CW	0	Counterclockwise
	1	Clockwise

4-Point Calibration Mode

The SC69411 allows the user to divide the output curve through 4 points into up to 5 segments using the 4-point calibration mode, allowing the number of calibration points to be reduced to 2 or 3. The Y coordinate (-50%~100%) and X coordinate (0°~360°) of the 4 calibration points, and the slope of the 5 segments (LNR_S0,LNR_S1,LNR_S2,LNR_S3,LNR_S4) are fully set by the user. . To calculate the slope, two endpoints of the curve, 0 degree start and 360 degree end, are needed to calculate LNR_S0 and LNR_D_S.

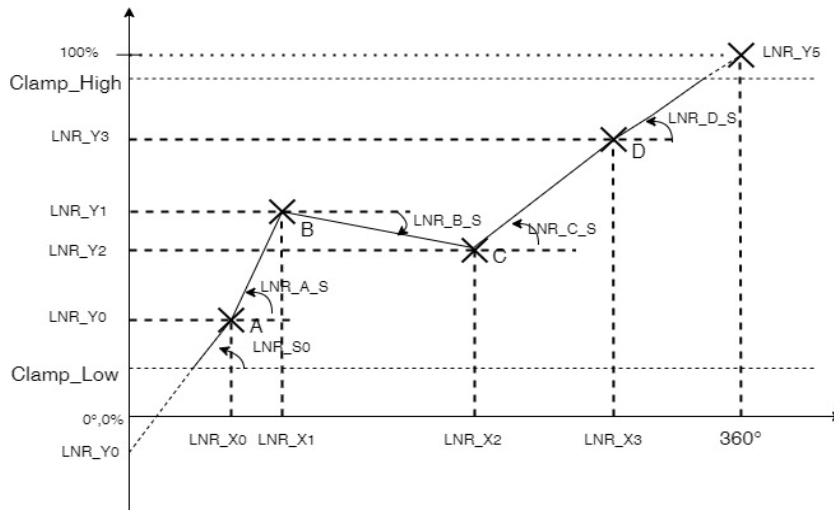

Fig.24 4-point calibration plot

8-Point Arbitrary Point Calibration Mode

The SC69411 allows the user to program the output curve desired by the user by customizing the X-coordinate ($0^\circ \sim 360^\circ$) and Y-coordinate (0%~100%) of any 8 calibration points. However, the slope cannot be set and can only be calculated from two neighboring points. A default fixed calibration point $[0^\circ, 0\%]$ is also required as a starting point.

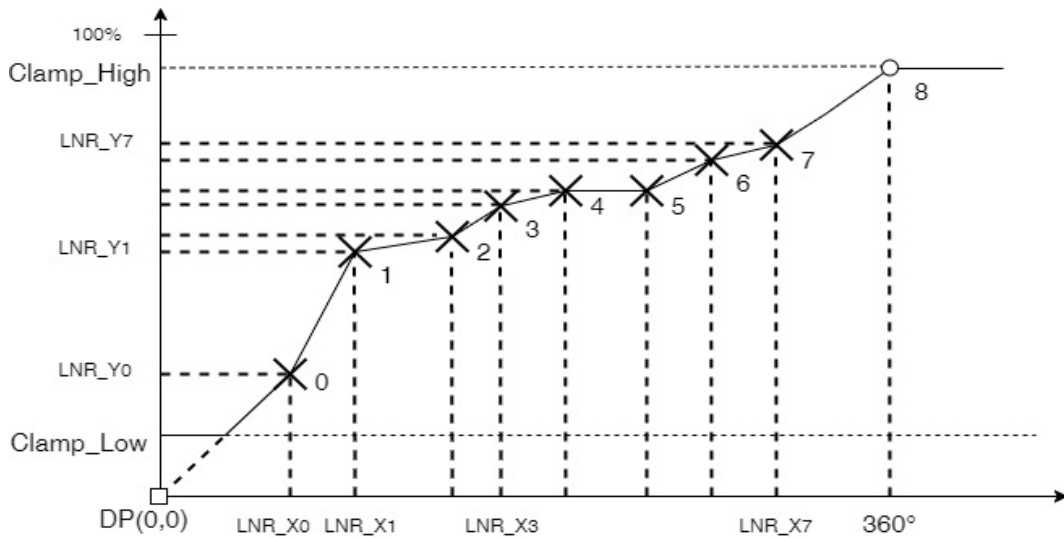

Fig.25 8-point calibration plot

16-Point Calibration Mode

The 16-point calibration mode allows the user to set only the Y-axis value of the coordinate point. x-axis coordinates are defined by the W value, which is divided into 16 segments within the WORK_RANGE range. y-point coordinates are allowed to range from -50% to +150% of the clamped voltage, which allows the clamped voltage to be in-between a certain segment (as shown in the following figure). But the output is still clamped voltage.

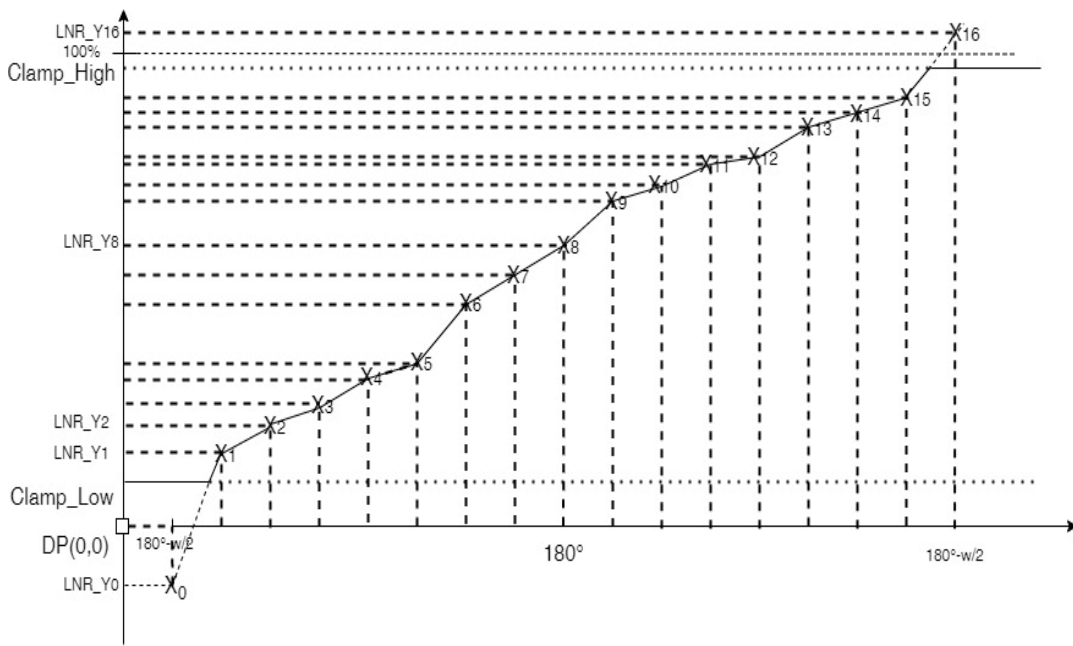

Fig.26 16-point calibration plot

32-point calibration mode

The work range W is defined by Workrange and is divided into 32 segments centered at 180° . The Y-axis coordinates consist of only 8 bits of data, so they are not absolute values but incremental coordinates. The two endpoints are $(180^\circ-w/2, 0\%)$ and $(180^\circ+w/2, 100\%)$ to define an ideal curve, and ΔY is the fine-tuned value of Y corresponding to the X coordinate of the horizontal axis.

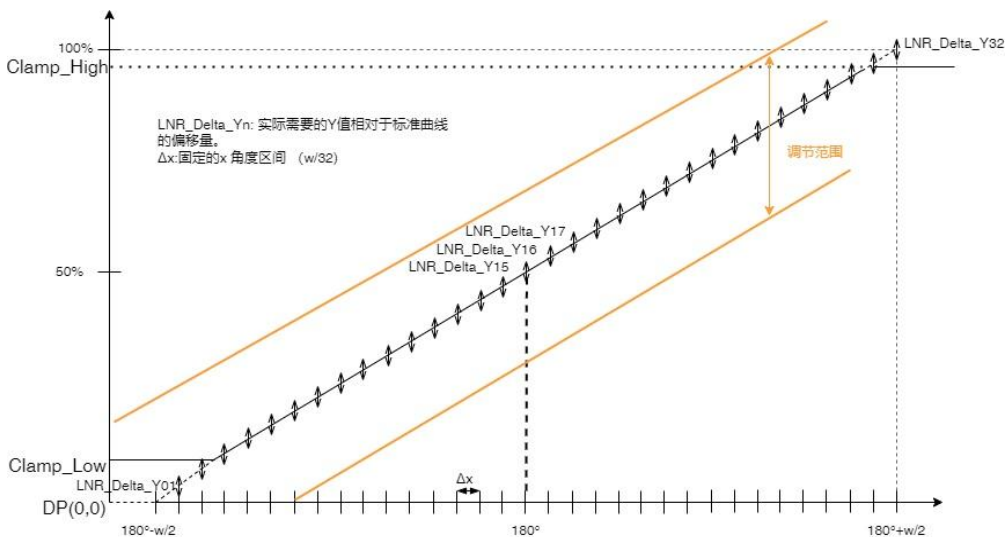

Fig.27 32-point calibration plot

32-point calibration, Y-axis coordinate deviation range setting

Parameters	Value	Description
LNR_DELTA_Y_EXPAND [1:0]	0	Tolerance range $\pm 3.125\%$
	1	Tolerance range $\pm 6.25\%$
	2	Tolerance range $\pm 12.5\%$
	3	Tolerance range $\pm 25\%$

Angle Range Selection

$$w = \frac{WORK_RANGE_GAIN \times 360^\circ}{0XFFFF}$$

$$\text{Angular range } \theta_{min} = \frac{360^\circ - w}{2} \quad \theta_{max} = \frac{360^\circ + w}{2}$$

θ_{min} indicates the angle at 0% output, and θ_{max} indicates the angle at 100% output. In order to correct the output properly, the angle range needs to be set to an integer multiple greater than 16.

Example of angular range setting:

<i>WORK_RANGE_GAIN</i>	<i>w</i> (°)	θ_{min} (°)	θ_{max} (°)	ΔX , 16pts(°)	ΔX , 32pts(°)
0x1000	22.50034	168.7498	191.2502	1.406271	0.703136
0x1100	23.90661	168.0467	191.9533	1.494163	0.747082
0x1200	25.31289	167.3436	192.6564	1.582055	0.791028
0x1300	26.71916	166.6404	193.3596	1.669947	0.834974
0x2000	45.00069	157.4997	202.5003	2.812543	1.406271
0x2100	46.40696	156.7965	203.2035	2.900435	1.450217
0x2200	47.81323	156.0934	203.9066	2.988327	1.494163
0x2300	49.2195	155.3902	204.6098	3.076219	1.538109
0x3000	67.50103	146.2495	213.7505	4.218814	2.109407
0x3100	68.9073	145.5463	214.4537	4.306706	2.153353
0x3200	70.31357	144.8432	215.1568	4.394598	2.197299
0x3300	71.71984	144.1401	215.8599	4.48249	2.241245
0x4000	90.00137	134.9993	225.0007	5.625086	2.812543
0x4100	91.40764	134.2962	225.7038	5.712978	2.856489
0x4200	92.81392	133.593	226.407	5.80087	2.900435
0x4300	94.22019	132.8899	227.1101	5.888762	2.944381
0xFA00	351.5679	4.216068	355.7839	21.97299	10.9865
0xFB00	352.9741	3.512932	356.4871	22.06088	11.03044
0xFC00	354.3804	2.809796	357.1902	22.14878	11.07439
0xFD00	355.7867	2.106661	357.8933	22.23667	11.11833
0xFE00	357.193	1.403525	358.5965	22.32456	11.16228
0xFF00	358.5992	0.700389	359.2996	22.41245	11.20623
0xFFFF	360	0	360	22.5	11.25

11. Typical Application Circuit

Analog/PWM/SENT SOP8 Package Application Circuits

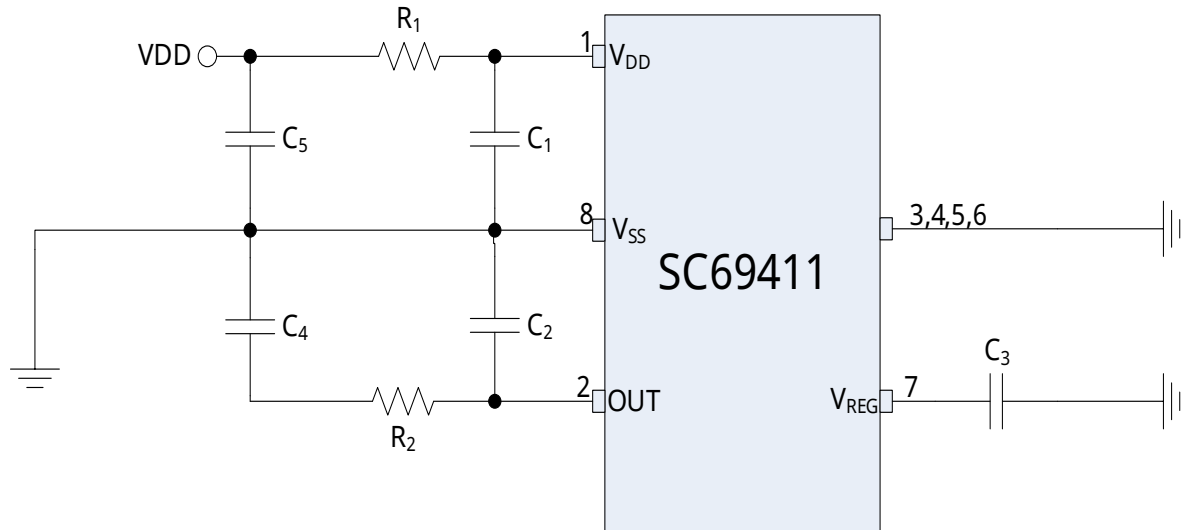

Fig.28 Analog/PWM/SENT SOP8 Reference Circuit Diagram

Analog Output Reference

Component	Min.	Typ.	Max.	Description
R1	-	0Ω	10Ω	Reducing the impact of EMC increases the output error
R2	-	0Ω	51Ω	Reduce the impact of EMC
C1	100nF	100nF	-	Placement near pins
C2	47nF	100nF	-	Placement near pins
C3	47nF	100nF	220nF	Placement near pins
C4	-	1nF	10nF	Reduce the impact of EMC and place it close to the connector end
C5	-	1nF	10nF	Reduce the impact of EMC and place it close to the connector end

Digital Output (PWM) Reference

Component	Min.	Typ.	Max.	Description
R1	-	0Ω	33Ω	Reducing the impact of EMC affects the output of high level
R2	-	0Ω	51Ω	Reducing the impact of EMC affects the output of high and low levels
C1	100nF	100nF	-	Placement near pins
C2	2.2nF	4.7nF	22nF	Placement near pins
C3	47nF	100nF	220nF	Placement near pins
C4	-	1nF	10nF	Reduce the impact of EMC and place it close to the connector end
C5	-	1nF	2.2nF	Reduce the impact of EMC and place it close to the connector end

Digital Output (SENT) Reference Value

Component	Min.	Typ.	Max.	Description
R1	-	0Ω	10Ω	Reducing the impact of EMC affects the output of high level
R2	-	-	-	
C1	100nF	100nF	-	Placement near pins
C2	1nF	4.7nF	22nF	Placement near pins
C3	47nF	100nF	220nF	Placement near pins
C4	-	1nF	10nF	Reduce the impact of EMC and place it close to the connector end
C5	-	-	1nF	Reduce the impact of EMC and place it close to the connector end

Analog/PWM/SENT TSSOP16 Package Application Circuit

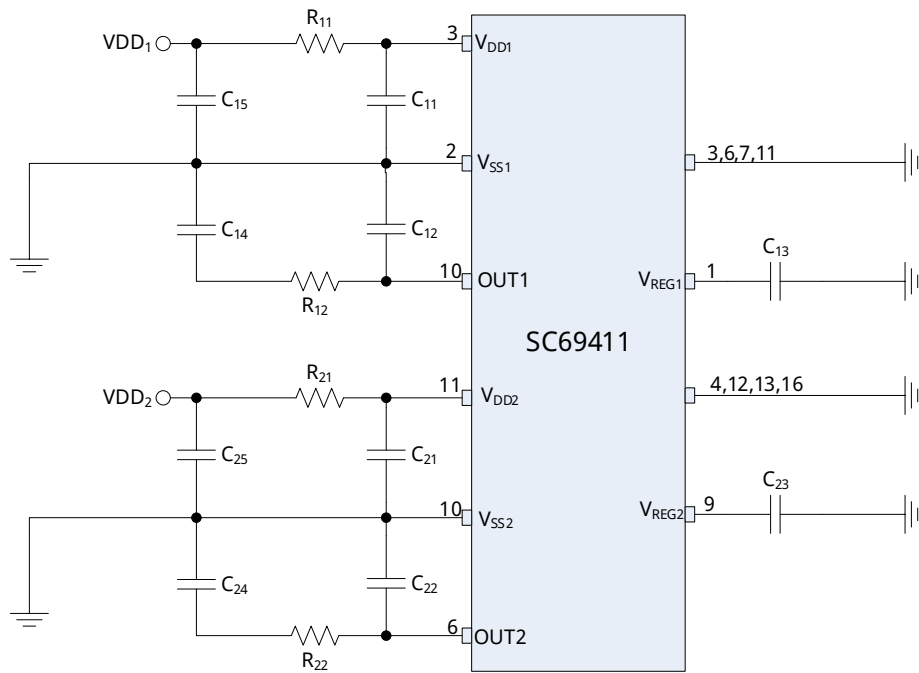

Fig.29 Analog/PWM/SENT TSSOP16 Reference Circuit Diagram

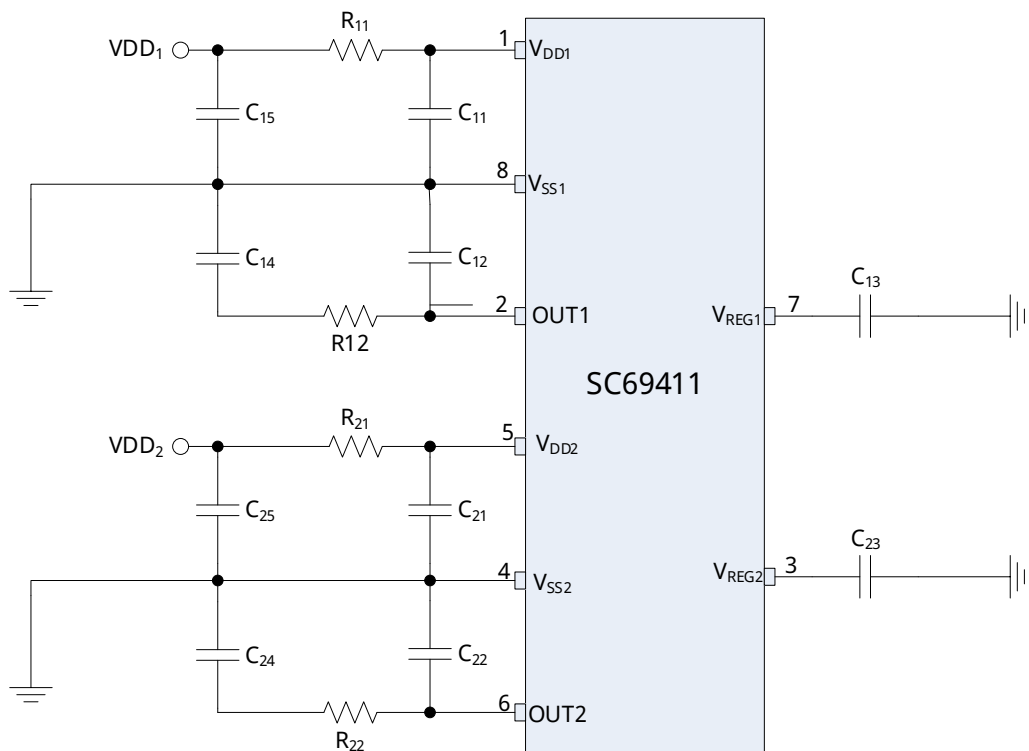

Fig.30 Analog/PWM/SENT SOP8 Reference Circuit Diagram

Analog Output Reference Value

Component	Min.	Typ.	Max.	Description
R11, R21	-	0Ω	10Ω	Reduces EMC effects and increases measurement errors
R12, R22	-	0Ω	51Ω	Reduces EMC effects and increases measurement errors
C11, C21	100nF	100nF	-	Placement near pins
C12, C22	47nF	100nF	-	Placement near pins
C13, C23	47nF	100nF	220nF	Placement near pins
C14, C24	-	1nF	10nF	Reduced EMC impact, placed close to the connector end
C15, C25	-	1nF	10nF	Reduced EMC impact, placed close to the connector end

Digital Output (PWM) Reference Value

Component	Min.	Typ.	Max.	Description
R ₁₁ , R ₂₁	-	0Ω	33Ω	Reduces EMC effects affecting the output high level
R ₁₂ , R ₂₂	-	0Ω	51Ω	Reduces EMC effects, affecting output high and low levels
C ₁₁ , C ₂₁	100nF	100nF	-	Placement near pins
C ₁₂ , C ₂₂	2.2nF	4.7nF	22nF	Placement near pins
C ₁₃ , C ₂₃	47nF	100nF	220nF	Placement near pins
C ₁₄ , C ₂₄	-	1nF	10nF	Reduced EMC impact, placed close to the connector end
C ₁₅ , C ₂₅	-	1nF	2.2nF	Reduced EMC impact, placed close to the connector end

Digital Output (SENT) Reference Value

Component	Min.	Typ.	Max.	Description
R ₁₁ , R ₂₁	-	0Ω	33Ω	Reduces EMC effects affecting the output high level
R ₁₂ , R ₂₂	-	-	-	
C ₁₁ , C ₂₁	100nF	100nF	-	Placement near pins
C ₁₂ , C ₂₂	1nF	4.7nF	22nF	Placement near pins
C ₁₃ , C ₂₃	47nF	100nF	220nF	Placement near pins
C ₁₄ , C ₂₄	-	1nF	10nF	Reduced EMC impact, placed close to the connector end
C ₁₅ , C ₂₅	-	-	1nF	Reduced EMC impact, placed close to the connector end

PSI5 SOP8 Package Application Circuit

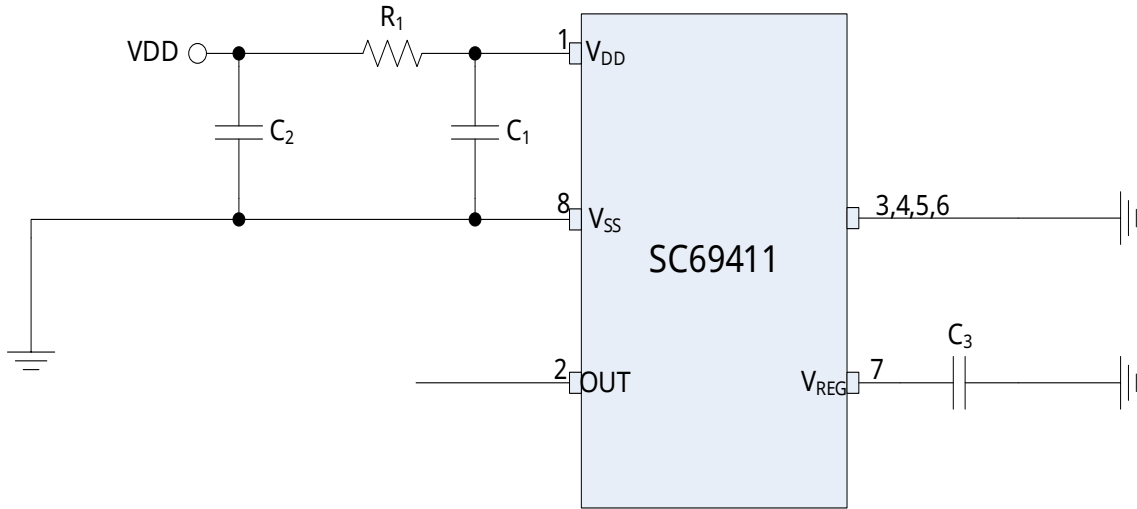

Fig.31 PSI5 SOP8 Reference Circuit Diagram

Component	Min.	Typ.	Max.	Description
R ₁	-	0Ω	10Ω	
C ₁	9nF	10nF	24nF	Placement near pins
C ₂	500pF	-	1nF	Reduced EMC impact, placed close to the connector end
C ₃	47nF	100nF	220nF	Placement near pins

SIP3 Single Package Application Circuit

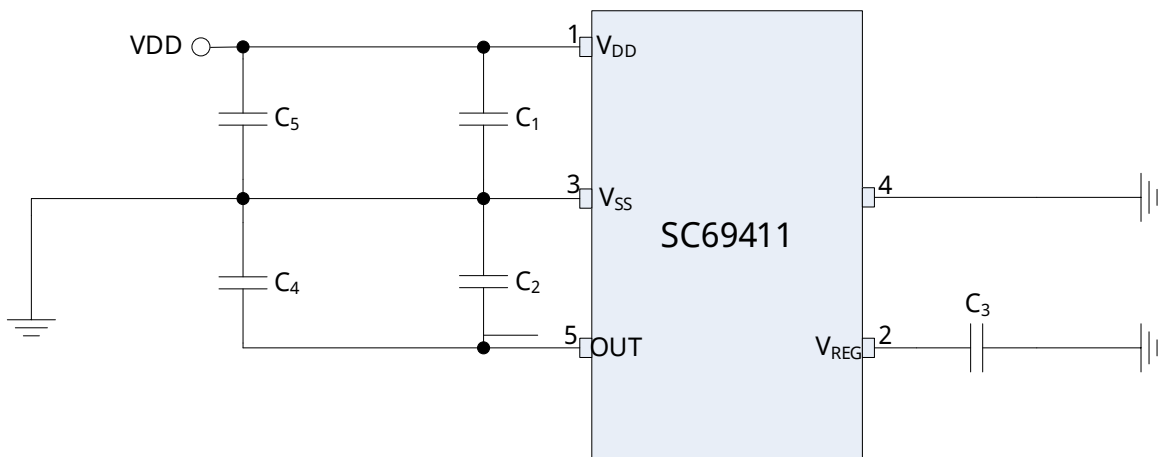
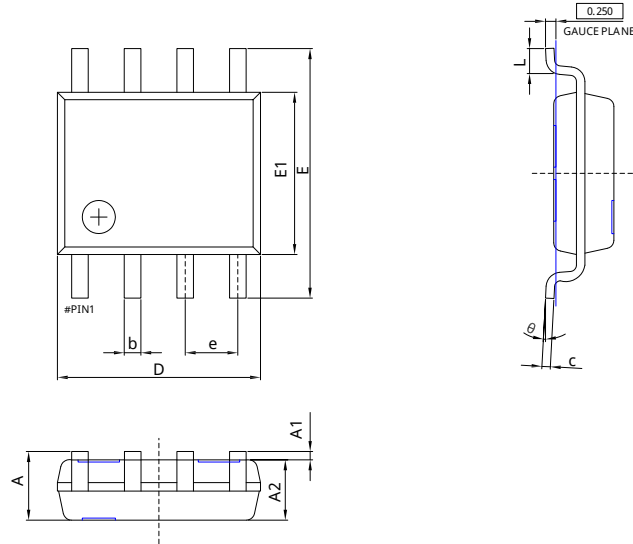

Fig.32 SIP3 Single Chip Reference Circuit Diagram

Component	Min.	Typ.	Max.	Description
Analog Output				
C ₁	-	100nF	-	
C ₂	-	100nF	-	
C ₃	-	100nF	-	
C ₁	-	100nF		
PWM Output				
C ₁	-	100nF	-	
C ₂	-	100nF	-	
C ₃	-	100nF	-	
C ₁	-	100nF		
SENT Output				
C ₁	-	100nF	-	
C ₂	-	100nF	-	
C ₃	-	100nF	-	
PSI5 Output				
C ₁	-	10nF	-	
C ₂	-	10nF	-	
C ₃	-	100nF		

12. Packaging Information

12.1 SOP8 Package Type(DC)



Symbol	Dimensions In Millimeters		Dimensions In Inches	
	Min.	Max.	Min.	Max.
A	1.450	1.750	0.057	0.069
A1	0.100	0.250	0.004	0.010
A2	1.350	1.550	0.053	0.061
b	0.330	0.510	0.013	0.020
c	0.170	0.250	0.007	0.010
D	4.700	5.100	0.185	0.201
E	5.800	6.200	0.228	0.244
E1	3.800	4.000	0.150	0.157
e	1.270(BSC)		0.050(BSC)	
L	0.400	1.270	0.016	0.050
θ	0°	8°	0°	8°

Fig.33 SOP8 package dimensions

12.2 TSSOP16 Package Type(TG)

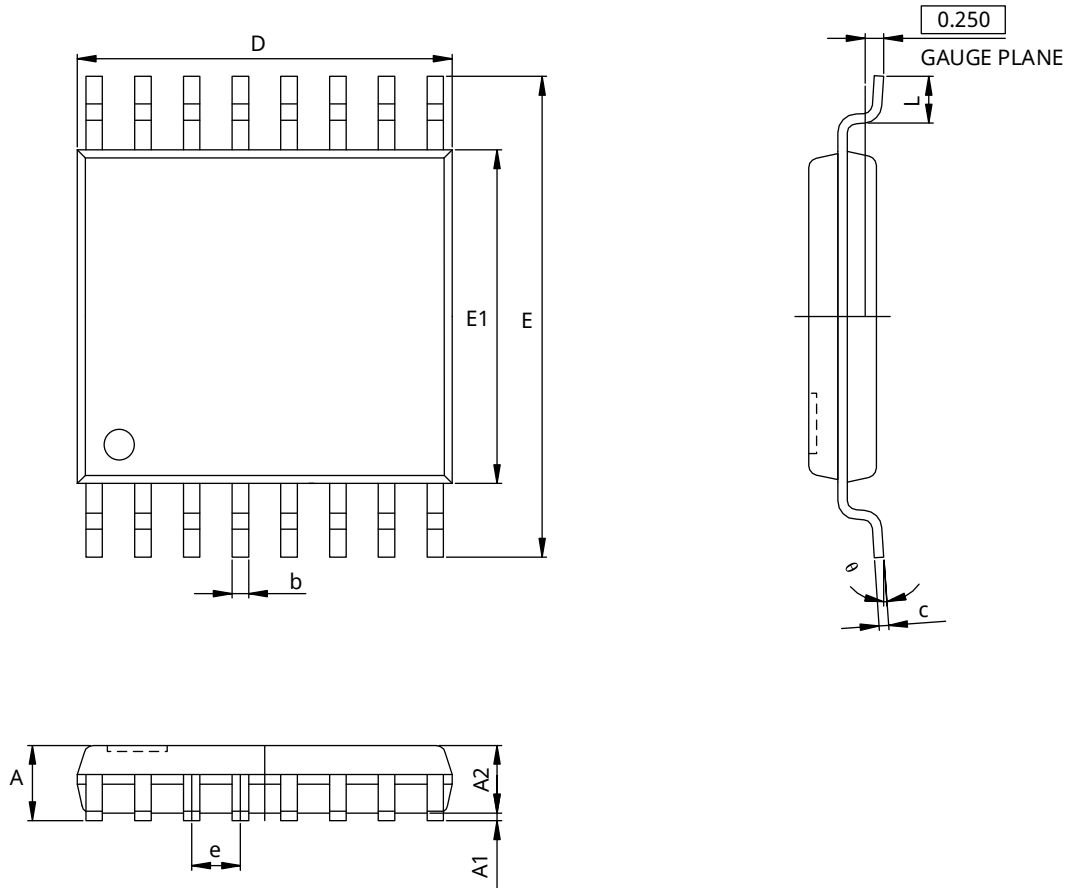

Symbol	Dimensions In Millimeters		Dimensions In Inches	
	Min.	Max.	Min.	Max.
A	-	1.200	-	0.047
A1	0.050	0.150	0.002	0.006
A2	0.800	1.000	0.031	0.039
b	0.190	0.300	0.007	0.012
c	0.090	0.200	0.004	0.008
D	4.900	5.100	0.193	0.201
E	6.250	6.550	0.252(BSC)	
E1	4.300	4.500	0.169	0.177
e	0.650(BSC)		0.026(BSC)	
L	0.500	0.700	0.020	0.028
θ	1°	7°	1°	7°

Fig.34 TSSOP16 package dimensions

12.3 SIP3 Package Type(S3)

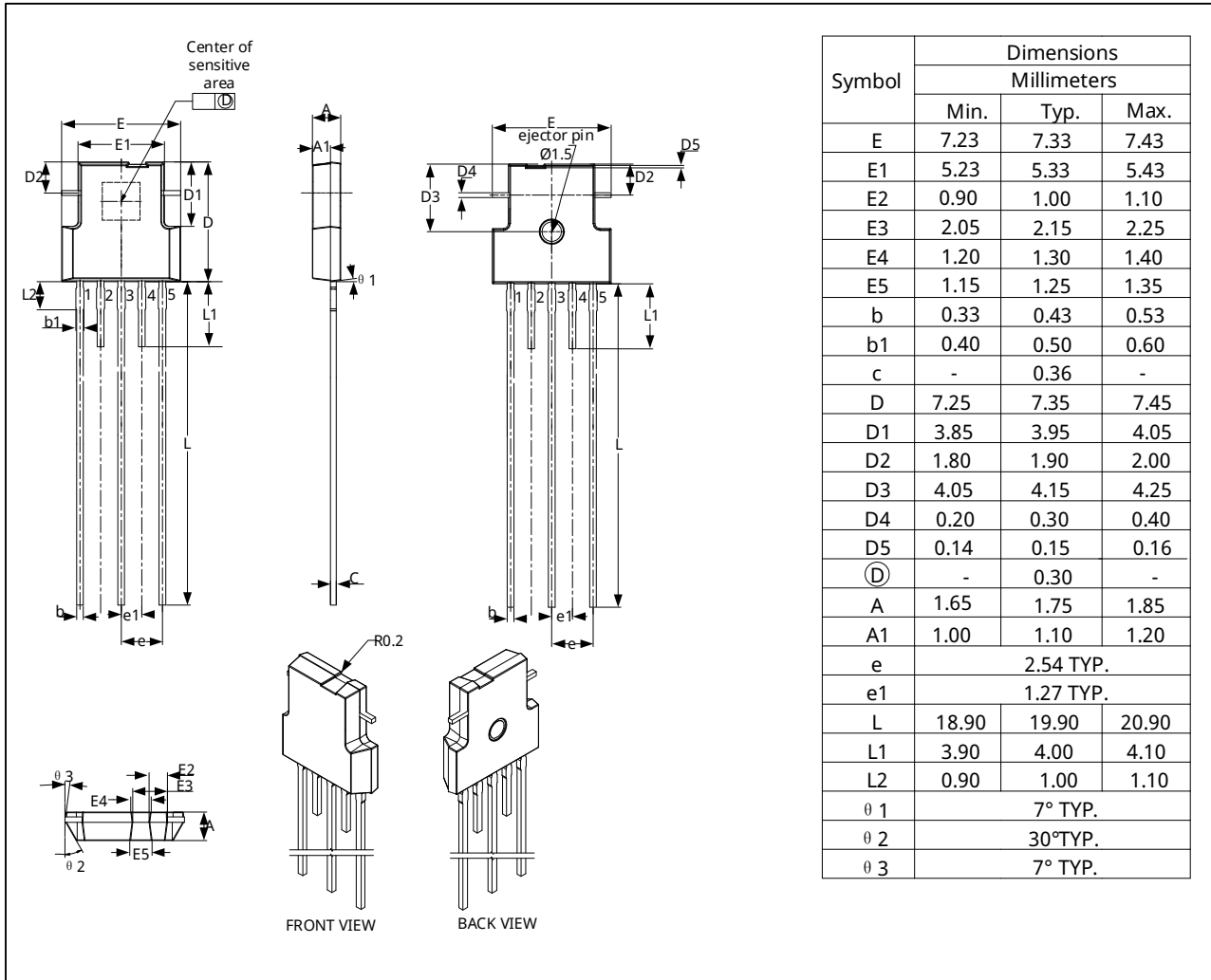
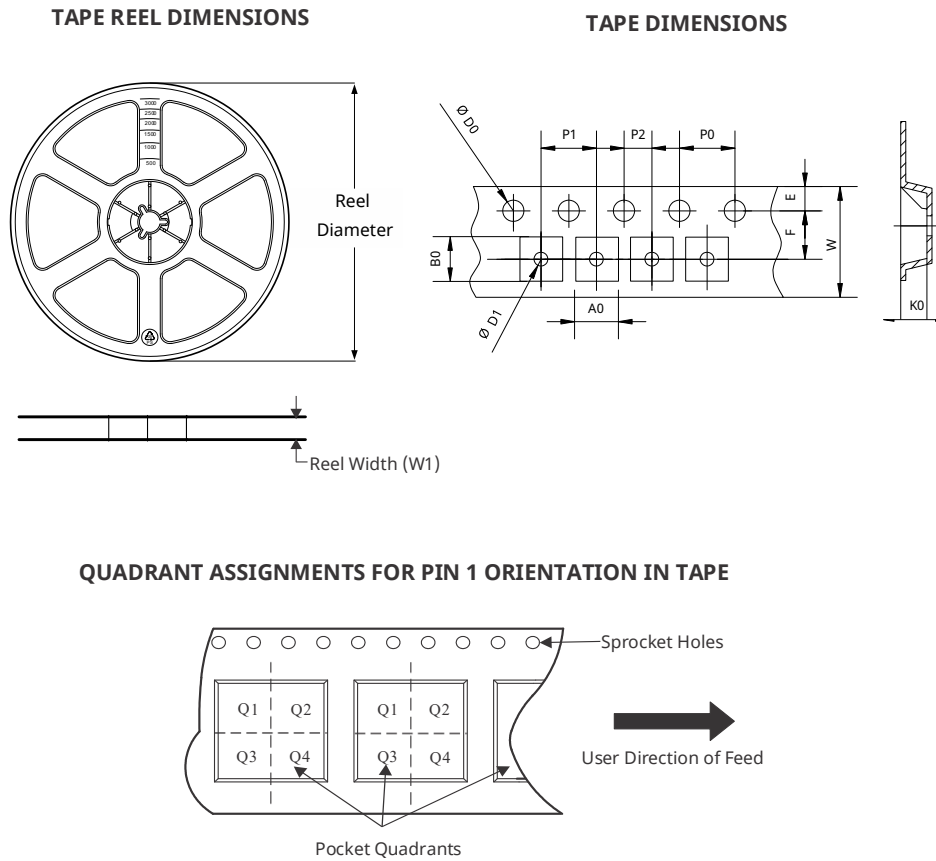

Fig.35 SIP3 package dimensions

13. Packing Information

13.1 SOP8 Tape&Reel Dimensions



*All dimensions are nominal

Package Type	SPQ	Reel Diameter (mm)	Reel Width W1 (mm)	P0 (mm)	P1 (mm)	P2 (mm)	A0 (mm)	B0 (mm)	K0 (mm)	W (mm)	Pin1 Quadrant
SOP8	4000	330	13.0	4.00	8.00	2.00	6.40	5.40	2.10	12.00	Q1

Fig.36 SOP8 Tape&Reel dimensions

13.2 TSSOP16 Tape&Reel Dimensions

TAPE REEL DIMENSIONS

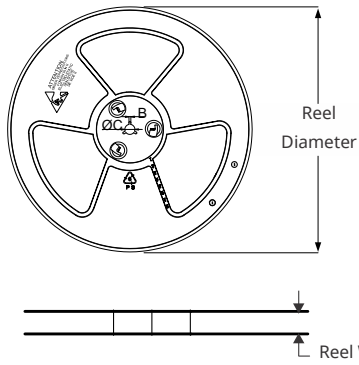

TAPE DIMENSIONS

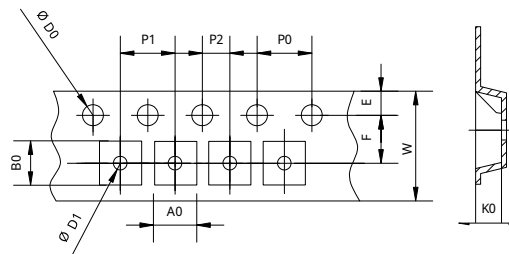

QUADRANT ASSIGNMENTS FOR PIN 1 ORIENTATION IN TAPE

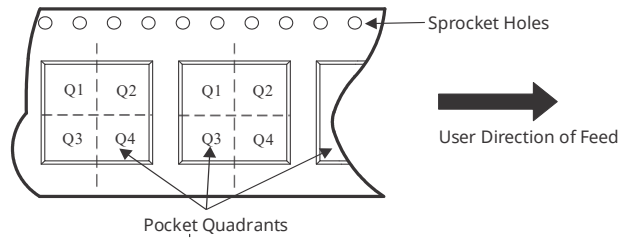

*All dimensions are nominal

Package Type	SPQ	Reel Diameter (mm)	Reel Width W1 (mm)	P0 (mm)	P1 (mm)	P2 (mm)	A0 (mm)	B0 (mm)	K0 (mm)	W (mm)	Pin1 Quadrant
TSSOP16	3000	330	16.4	4	8.00	2.00	6.80	5.40	1.60	16.00	Q1

Fig.37 TSSOP16 Tape&Reel dimensions

13.3 SIP3 Tape&Reel Dimensions

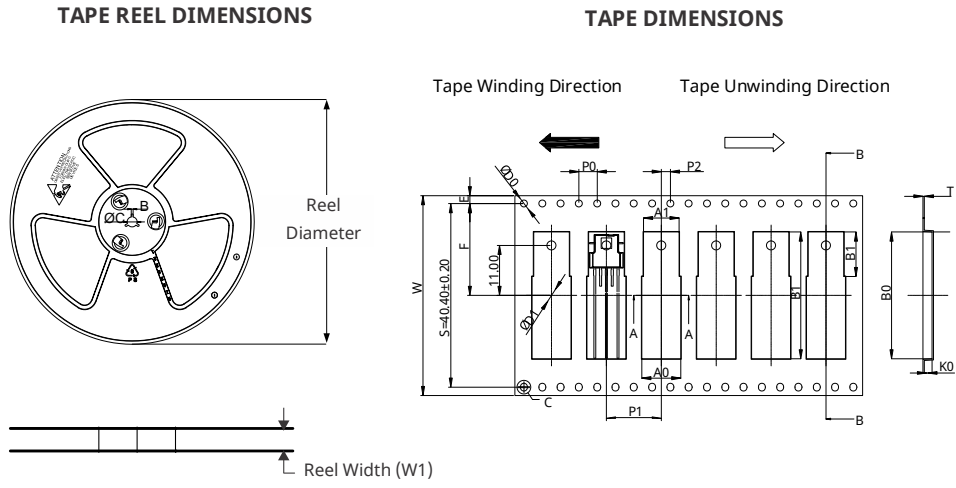

*All dimensions are nominal

Package Type	Reel Diameter (mm)	Reel Width W1 (mm)	P0 (mm)	P1 (mm)	P2 (mm)	A0 (mm)	B0 (mm)	K0 (mm)	W (mm)
SIP-3L	330	44.5	4.00	12.00	2.00	8.50	27.90	2.00	44.00

Fig.38 SIP3 Tape&Reel dimensions

14. Revision History

Revision	Date	Description
Rev.V0.1	2025-08-26	Initial draft
Rev.V0.2	2026-03-24	Increase the packaging size, update the SIP3 dimension drawing, and add a disclaimer

Notice and Disclaimer

The information, data, and specifications set out in this document (the "Document") are provided "AS IS" and for reference purposes, they shall not be construed as any warranty or authorization, whether express or implied, including but not limited to warranties of accuracy, completeness, merchantability, fitness for a particular purpose, or non-infringement of any third party's intellectual property rights.

Users of this Document are solely responsible for the selection, use, and application of SEMIMENT products, as well as for ensuring the safety of such applications. Users shall comply with all applicable laws, regulations, and requirements related to the use of SEMIMENT products. Any application-related information or support that may be provided by SEMIMENT is for reference only and does not constitute any guarantee or liability.

The resources described in this Document are subject to change without notice. SEMIMENT grants permission to use these resources solely for the development of applications incorporating SEMIMENT products as described herein. Any other reproduction, distribution, or public display of these resources is prohibited without prior written consent. No license, express or implied, is granted under any SEMIMENT intellectual property rights or any third-party intellectual property rights.

You agree to defend, indemnify and hold harmless SEMIMENT and its representatives from and against any claims, damages, costs, losses, or liabilities arising from your use of these resources.

For the latest product information and technical support, please contact SEMIMENT (www.semiment.com).

Copyright © Semiment Technology Co.,Ltd