

# High Sensitive Digital-Bipolar Hall Effect Sensor

## 1. Features

- Ultra-high sensitivity
- High chopping frequency
- Supports a wide voltage range: 2.5~18V
- Wide operating temperature range:  
-40~125°C
- Solid-state reliability
- Small package
  - 3-pin TO-92S (UA)
  - 3-pin SOT23-3L (SO)
  - 6-pin DFN1616 -(DN)

## 2. Applications

- Automotive and Industrial
- BLDC motor commutation
- Seat motor sensor
- Window lifter sensor
- Sunroof/Tailgate sensor
- Tachometers

## 3. Description

The SC2402 is a Hall-effect latch designed in mixed signal BiCMOS technology. The device integrates a voltage regulator, Hall sensor with dynamic offset cancellation system, Schmitt trigger and an open-drain output driver, all in a single package.

The low operating voltage and extended choice of temperature range make it suitable for use in automotive, industrial and consumer low voltage applications.

An onboard regulator permits with supply voltages of 2.5 to 18V which makes the device suitable for a wide range of industrial and automotive applications

These devices are available in a 3-pin SIP package (UA), a 3-pin SOT-23 package (SO) And a 6-pin DFN1616 package (DN) . Both packages are lead (Pb) free, with 100% matte tin lead frame plating.



Fig.1 Package Outline

## CONTENTS

<b>1. Features</b> .....	<b>1</b>	<b>10. Typical Characteristics</b> .....	<b>8</b>
<b>2. Applications</b> .....	<b>1</b>	<b>11. Block Diagram</b> .....	<b>10</b>
<b>3. Description</b> .....	<b>1</b>	<b>12. Function Description</b> .....	<b>10</b>
<b>4. Terminal Configuration</b> .....	<b>3</b>	<b>12.1. Field Direction Definition</b> .....	<b>11</b>
<b>5. Ordering Information</b> .....	<b>4</b>	<b>12.2. Transfer Function</b> .....	<b>11</b>
<b>6. Absolute Maximum Ratings</b> .....	<b>5</b>	<b>13. Typical Application</b> .....	<b>12</b>
<b>7. ESD Protection</b> .....	<b>5</b>	<b>14. Package Information "UA"</b> .....	<b>13</b>
<b>8. Thermal Characteristics</b> .....	<b>5</b>	<b>15. Package Information "DN"</b> .....	<b>14</b>
<b>9. Operating Characteristics</b> .....	<b>6</b>	<b>16. Package Information "SO"</b> .....	<b>15</b>
<b>9.1. Electrical Characteristics</b> .....	<b>6</b>	<b>17. Revision History</b> .....	<b>16</b>
<b>9.2. Magnetic Characteristics</b> .....	<b>7</b>		

### 4. Terminal Configuration

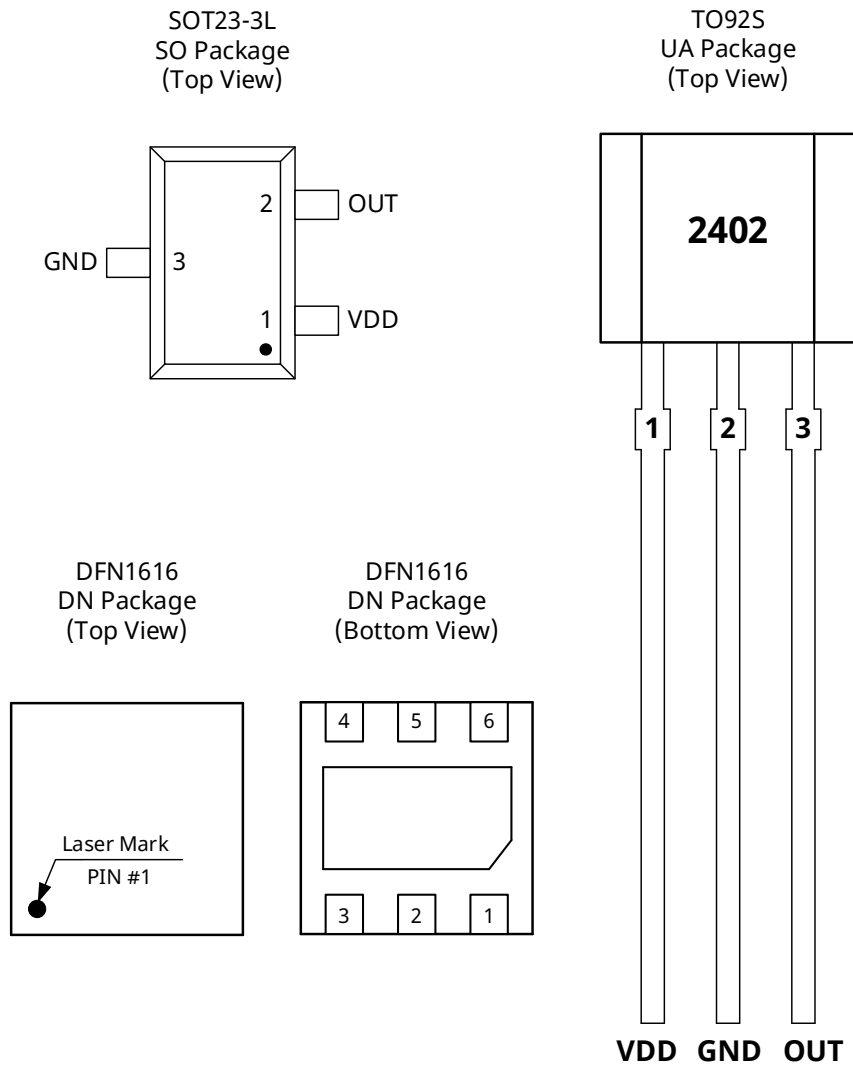

Fig. 2: Terminal Configuration

Terminal			Name	Type	Description
UA	SO	DN			
1	1	3	VDD	Power	2.5V ~ 18 V power supply
2	3	1	GND	Ground	Ground terminal
3	2	6	OUT	Output	Open-drain output. The open drain requires a pull-up resistor
-	-	2	NC	NC	Not connected
-	-	4	NC	NC	Not connected
-	-	5	NC	NC	Not connected

## 5. Ordering Information

Order Information	Mark	Option	Ambient, T <sub>A</sub> (°C)	Package	Packing	Quantity
SC2402DN-TR	2402		-40~125	DFN1616	TR	3000/reel
SC2402SO-N-TR	2402	N	-40~125	SOT23-3L	TR	3000/reel
SC2402UA-BK	2402		-40~125	TO-92S	BK	1000/bag

### Ordering Information Format:

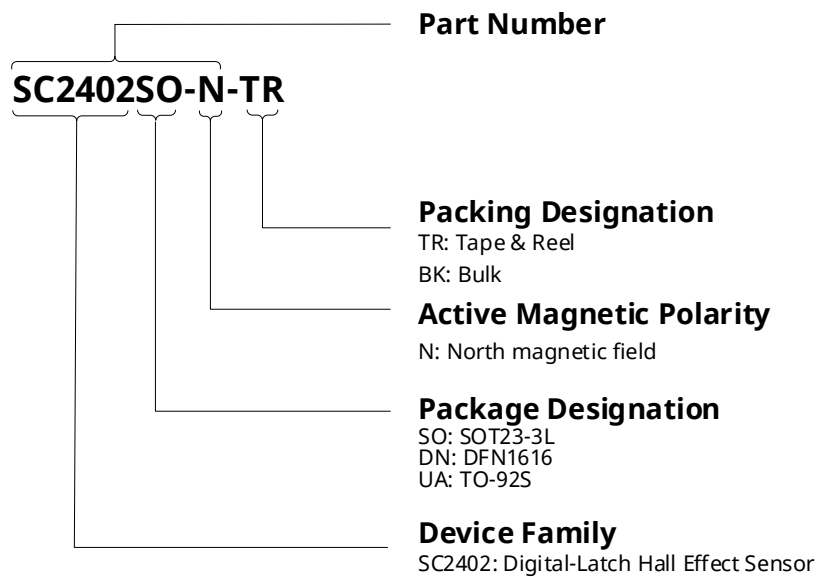

## 6. Absolute Maximum Ratings

over operating free-air temperature range (unless otherwise noted) <sup>(1)</sup>

Symbol	Parameter	Test Condition	Min.	Max.	Units
V <sub>DD</sub>	Power supply voltage		-10	20	V
V <sub>OUT</sub>	Output terminal voltage	For 5 Min. @1.2K pull-up resistor	-0.5	20	V
I <sub>SINK</sub>	Output terminal current sink		0	30	mA
T <sub>A</sub>	Operating ambient temperature		-40	125	°C
T <sub>J</sub>	Maximum junction temperature		-55	165	°C
T <sub>STG</sub>	Storage temperature		-65	175	°C

Note:

(1) Stresses above those listed here may cause permanent damage to the device. Exposure to absolute maximum rating conditions for extended periods may affect device reliability.

## 7. ESD Protection

Symbol	Parameter	Test Condition	Min.	Max.	Units
V <sub>ESD_HBM</sub>	HBM	according to: standard ANSI/ESDA/JEDEC-001	-3	3	kV
V <sub>ESD_CDM</sub>	CDM	according to: standard ANSI/ESDA/JEDEC-002	-750	750	V

## 8. Thermal Characteristics

Symbol	Parameter	Test Conditions	Rating	Units
R <sub>θJA</sub>	UA Package thermal resistance	Single-layer PCB, with copper limited to solder pads	166 <sup>(1)</sup>	°C/W
	SO Package thermal resistance	Single-layer PCB, with copper limited to solder pads	228 <sup>(1)</sup>	°C/W

Note:

(1) Maximum voltage must be adjusted for power dissipation and junction temperature, see Thermal Characteristics.

## 9. Operating Characteristics

### 9.1. Electrical Characteristics

over operating free-air temperature range ( $V_{DD} = 5.0V$ , unless otherwise noted)

Symbol	Parameter	Test Conditions	Min.	Typ. <sup>(1)</sup>	Max.	Units
$V_{DD}$	Operating voltage <sup>(2)</sup>	$T_J < T_{J(Max.)}$	2.5	5.0	18	V
$I_{DD}$	Operating supply current	$V_{DD}=2.5$ to $18$ V, $T_A=25^\circ\text{C}$	1.6	1.6	6.0	mA
$t_{on}$	Power-on time	$V_{DD} \geq 5.0V$	-	-	10	$\mu\text{s}$
$I_{QL}$	Off-state leakage current	Output Hi-Z	-	-	3	$\mu\text{A}$
$R_{DS(on)}$	FET on-resistance	$V_{DD} = 5V, I_O = 10mA, T_A = 25^\circ\text{C}$	-	20	-	$\Omega$
		$V_{DD} = 5V, I_O = 10mA, T_A = 125^\circ\text{C}$	-	30	-	$\Omega$
$t_d$	Output delay time	$B=B_{RP}$ to $B_{OP}$	-	15	25	$\mu\text{s}$
$t_r$	Output rise time (10% to 90%)	$R1=1\text{Kohm}$ $C_0=50\text{pF}$	-	-	0.5	$\mu\text{s}$
$t_f$	Output fall time (90% to 10%)	$R1=1\text{Kohm}$ $C_0=50\text{pF}$	-	-	0.2	$\mu\text{s}$

Note:

(1) Typical values are defined at  $T_A = 25^\circ\text{C}$  and  $V_{DD} = 5.0V$

(2) Maximum voltage must be adjusted for power dissipation and junction temperature, see Thermal Characteristics

## 9.2. Magnetic Characteristics

over operating free-air temperature range ( $V_{DD} = 5.0V$ , unless otherwise noted)

Symbol	Parameter	Test Conditions	Min.	Typ.	Max.	Units
$f_{BW}$	BW		20	-	-	kHz
<b>SC2402</b>						
$B_{OP}$	Operating point	$T_A = -40^{\circ}C$ to $125^{\circ}C$	+1.0 <sup>(1)</sup>	+2.0	+3.0	mT <sup>(2)</sup>
$B_{RP}$	Release point		-3.0	-2.0	-1.0	mT
$B_{HYS}$	Hysteresis		-	4.0	-	mT

Note:

(1) Magnetic flux density,  $B$  is indicated as a negative value for North-polarity magnetic fields, and as a positive value for South-polarity magnetic fields,

(2)  $1mT=10Gs$

### 10. Typical Characteristics

**$I_{DD}$  VS  $V_{DD}$**

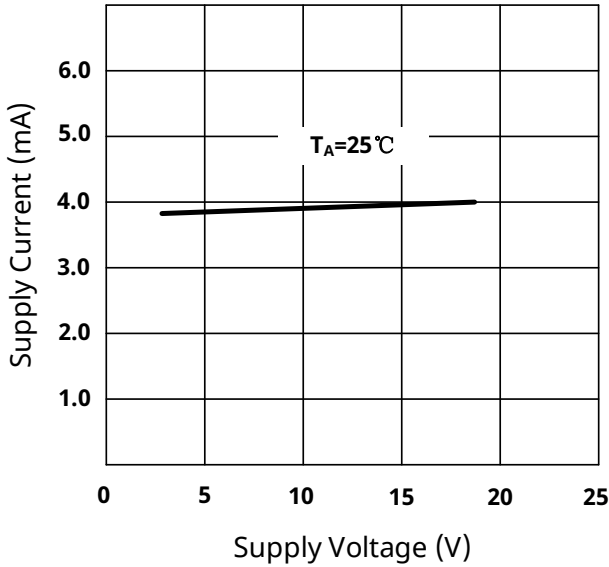

**$I_{DD}$  VS  $T_A$**

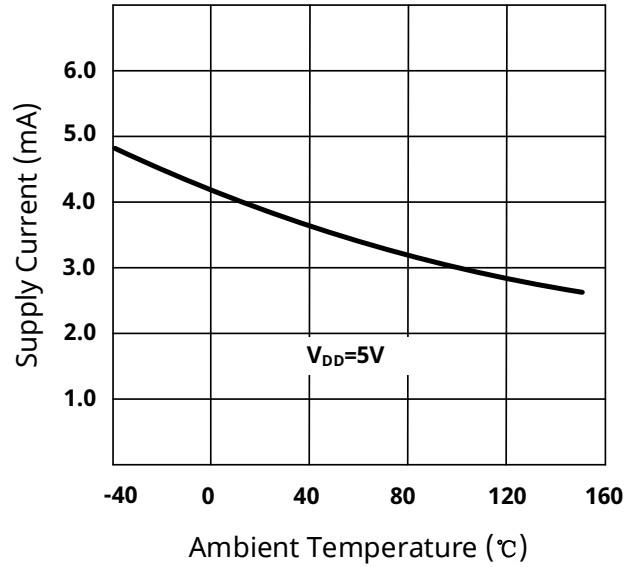

**$V_{Q(sat)}$  VS  $V_{DD}$**

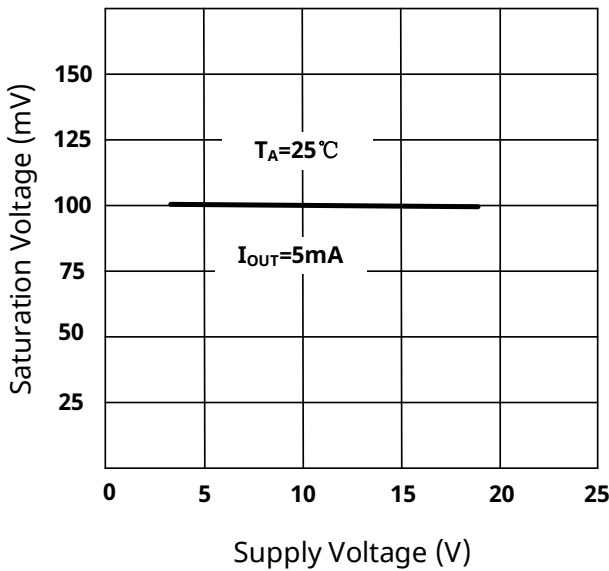

**$V_{Q(sat)}$  VS  $T_A$**

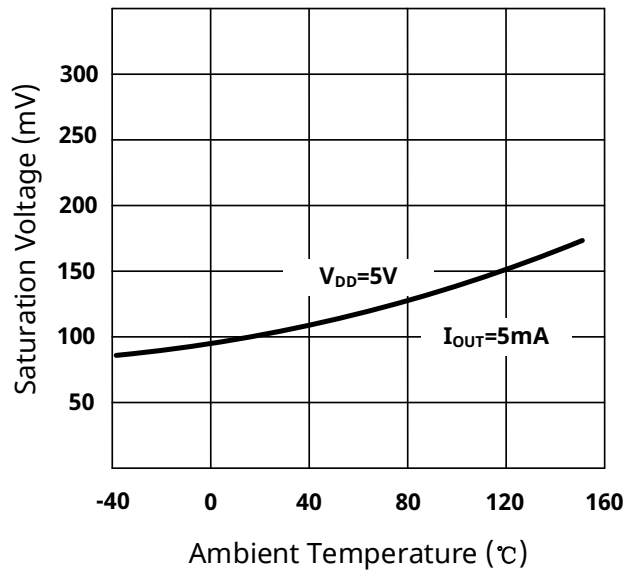

**$B_{OP}$  and  $B_{RP}$  vs  $T_A$**

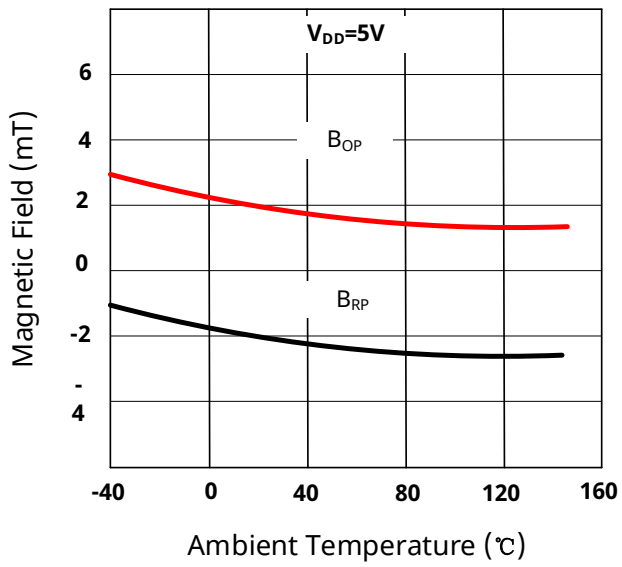

**$B_{HYS}$  vs  $T_A$**

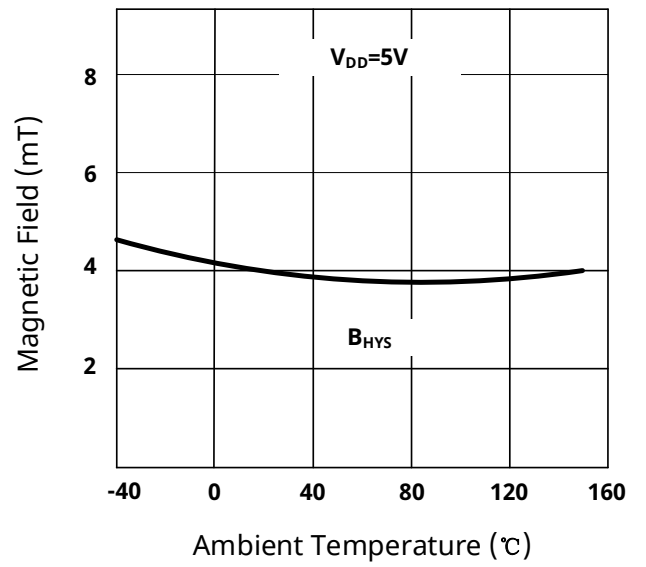

## 11. Block Diagram

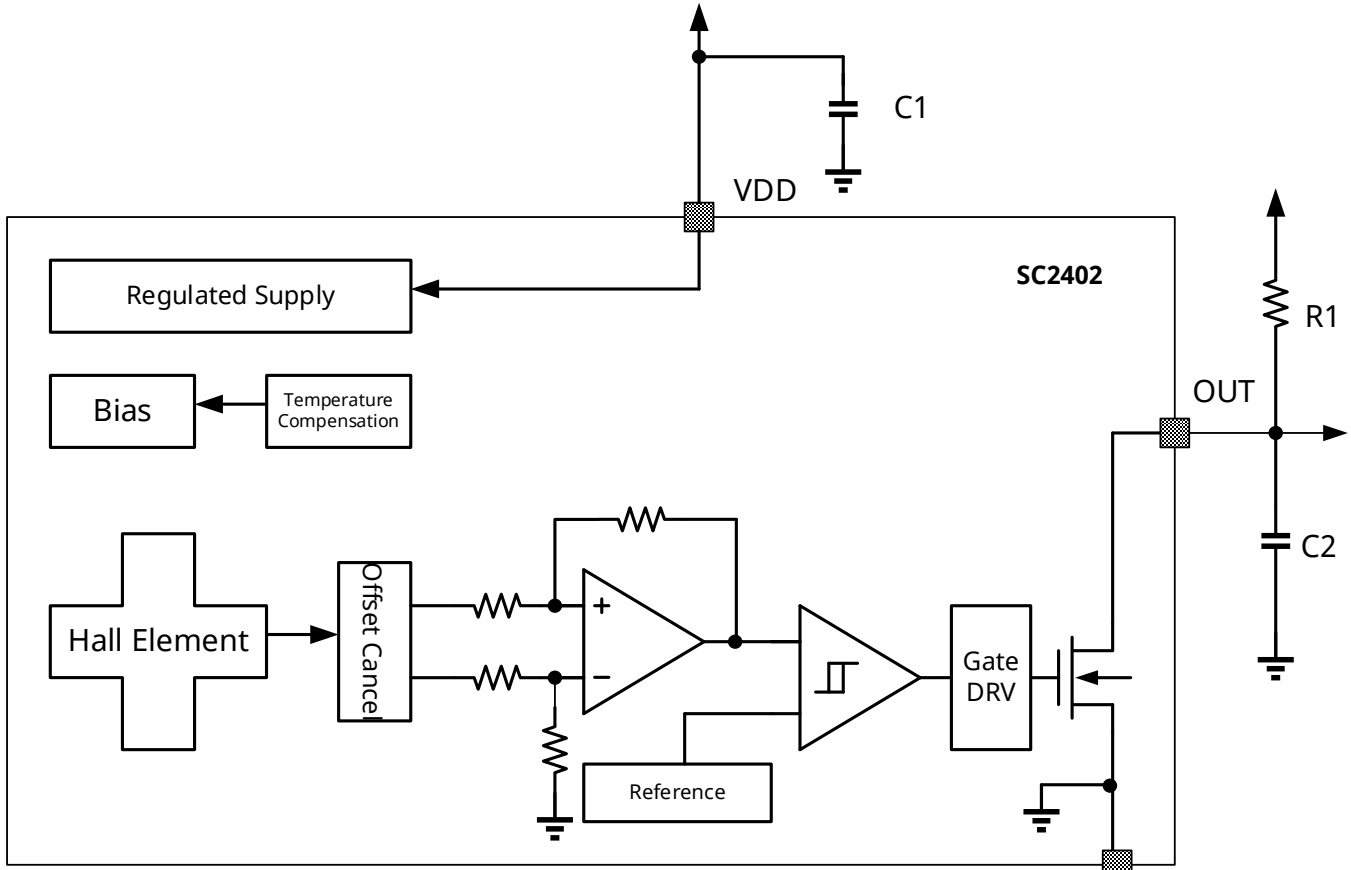

Fig. 3: Function Block Diagram

## 12. Function Description

The SC2402 device is a chopper-stabilized Hall sensor with a digital latched output for magnetic sensing applications. The device can be powered with a supply voltage between 2.5V and 18V. The device does not operate when -10 to 2.2V is applied to the VDD terminal (with respect to the GND terminal).

TO-92S package as an example, the output of SC2402 switches low (turns on) when a magnetic field (South polarity) perpendicular to the Hall element exceeds the operate point threshold,  $B_{OP}$ . After turn-on, the output is capable of sinking up to 20mA and the output voltage is  $V_{Q(sat)}$ . When the magnetic field is reduced below the release point,  $B_{RP}$ , the device output goes high (turns off). The difference in the magnetic operate and release points is the hysteresis,  $B_{HYS}$ , of the device. This built-in hysteresis allows clean switching of the output even in the presence of external mechanical vibration and electrical noise.

An external output pull-up resistor is required on the OUT terminal. The OUT terminal can be pulled up to  $V_{DD}$  or to a different voltage supply. This allows for easier interfacing with controller circuits.

### 12.1. Field Direction Definition

A positive magnetic field is defined as a South pole near the marked side of the package.

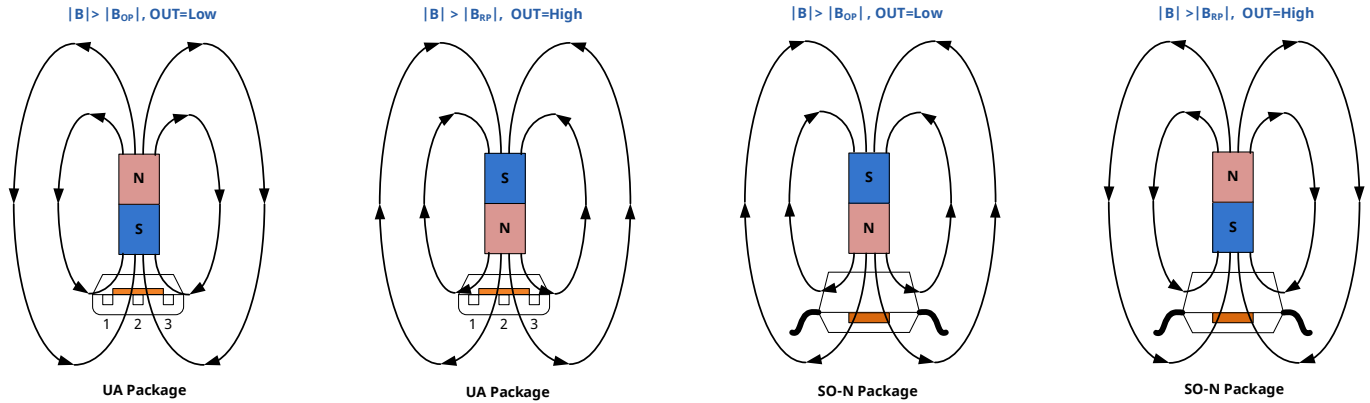

Fig. 4: Magnetic Field Direction Definition

### 12.2. Transfer Function

Powering-on the device in the hysteresis region, less than  $B_{OP}$  and higher than  $B_{RP}$ , allows an indeterminate output state. The correct state is attained after the first excursion beyond  $B_{OP}$  or  $B_{RP}$ .

TO-92S package as an example, if the field strength is greater than  $B_{OP}$ , then the output is pulled low. If the field strength is less than  $B_{RP}$ , the output is released.

$B_{OP}$ —magnetic threshold for activation of the device output, turning in ON (low) state

$B_{RP}$ —magnetic threshold for release of the device output, turning in OFF (high) state.

$$B_{HYS} = B_{OP} - B_{RP}$$

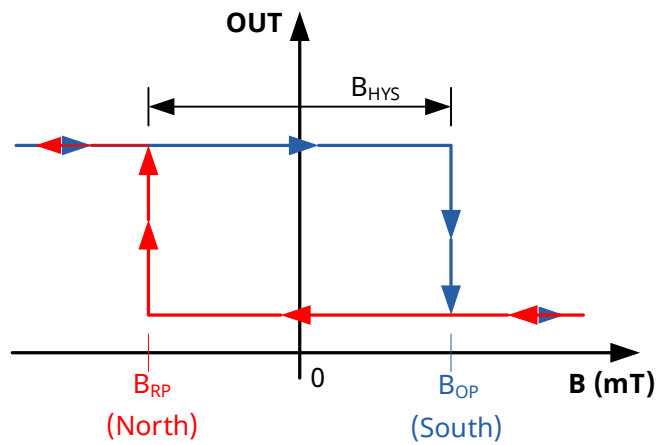

Fig. 5: TO-92S (UA) Package Magnetic Transfer Function

### 13. Typical Application

$R_1$  &  $R_2$  are the current limit resistor for the SC2402 chipset application, It is highly recommend to add  $R_1$  and  $R_2$  in application circuit, especially  $R_2$ .

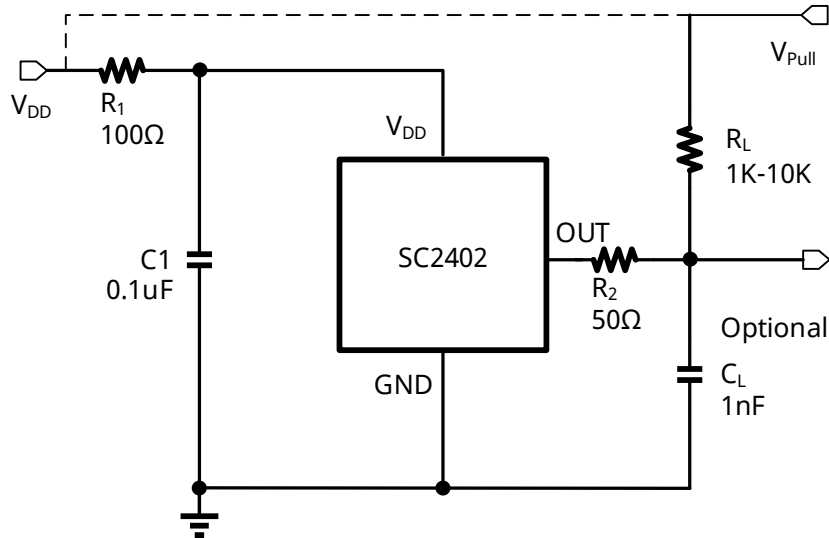

Fig. 6: Typical Application Circuit

The SC2402 contains an on-chip voltage regulator and can operate over a wide supply voltage range. In applications that operate the device from an unregulated power supply, transient protection must be added externally. For applications using a regulated line, EMI/RFI protection may still be required. It is recommended that C1 capacitor be connected to the ground in parallel near the  $V_{DD}$  power end of the chip, with a typical value of 0.1 $\mu$ F. At the same time in the external optional series resistor  $R_1$  and output capacitance  $C_L$  used for enhanced protection circuit, its typical values for 100 $\Omega$  and 1nF.

The SC2402 device output stage uses an open-drain NMOS, and it is rated to sink up to 20mA of current. For proper operation, calculate the value of the pull-up resistor  $R_L$  is required. The size of  $R_L$  is a tradeoff between OUT rise time and the load capacity when OUT is pulled low. A lower current is generally better, however faster transitions and bandwidth require a smaller resistor for faster switching.

Select a value for  $C_L$  based on the system bandwidth specifications such as:

$$C_L < \frac{1}{2\pi \times R_L \times 2 \times f_{BW}(Hz)}$$

$V_{PULL}$  is not restricted to  $V_{DD}$ , and could be connected to other voltage reference. The allowable voltage range of this terminal is specified in the Absolute Maximum Ratings.

### 14. Package Information "UA"

3-Terminal  
S3 Package

Dimension:mm

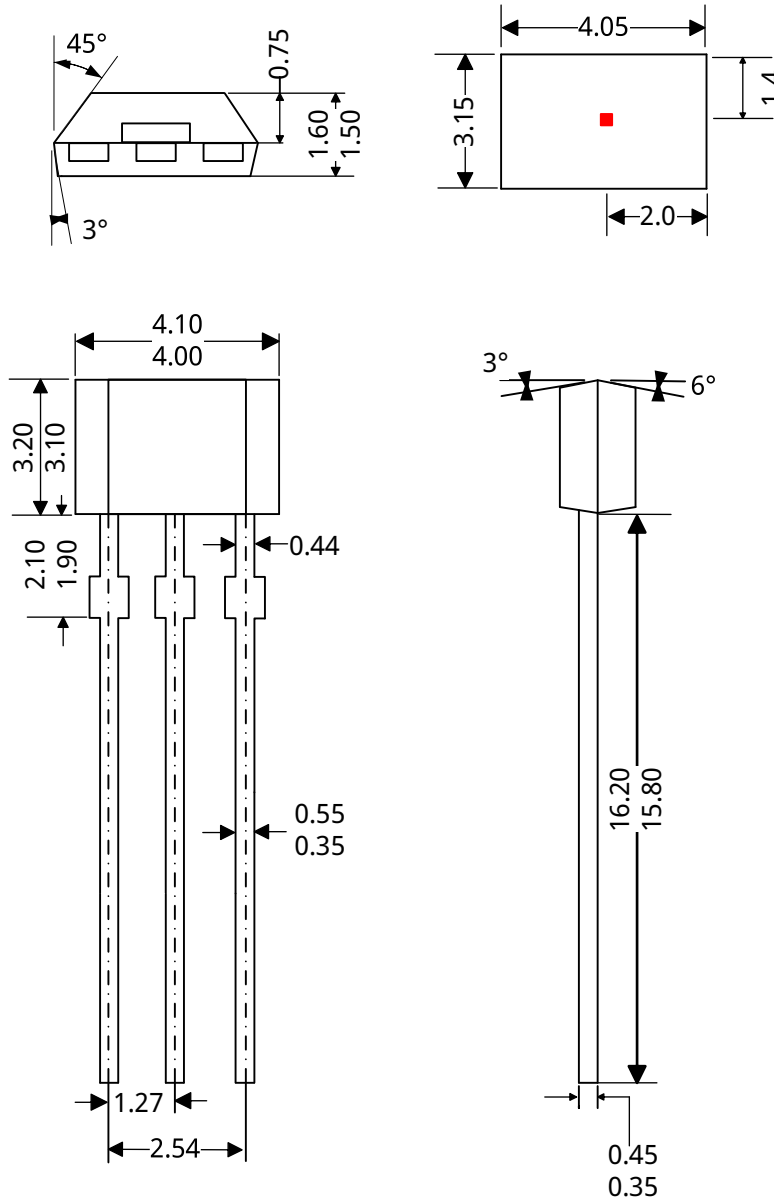

**Notes:**

1. Exact body and lead configuration at vendor's option within limits shown.
2. Height does not include mold gate flash.

Where no tolerance is specified, dimension is nominal.



### 16. Package Information "SO"

3-Terminal  
SO Package

Dimension:mm

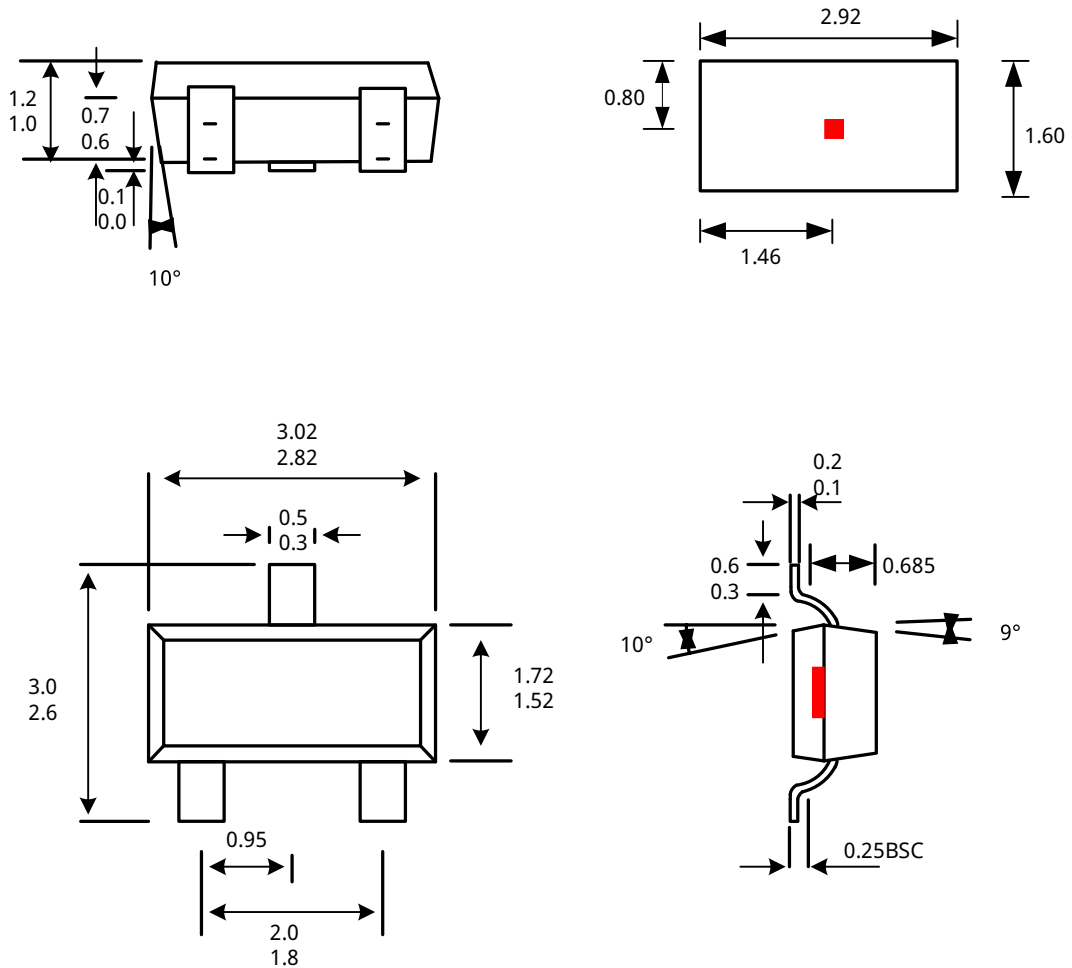

**Notes:**

1. Exact body and lead configuration at vendor's option within limits shown.
2. Height does not include mold gate flash.
3. The red mark is Hall element.

Where no tolerance is specified, dimension is nominal.

## 17. Revision History

Revision	Date	Description
Rev1.0	2016-05-10	Preliminary datasheet
Rev2.0	2019-05-06	The final revision of old datasheet
RevA/1.0	2024-02-21	Add DFN package information
RevA/1.1	2025-03-17	Modify the order information