

# Two-Wire Programmable Hall Effect Switches IC

## 1. Features

- AEC-Q100 grade 0
- ISO26262 ASIL B
- Two-wire current-type output interface
  - Provincial line
  - Open and short circuit diagnosis
- Programmable parameters:
  - Low current 3.3mA/6mA programmable
  - Unipolar or Omnipolar
  - Sensitivity range: -22mT to 22mT
  - Active Pole: orth or South
  - Output: Direct or Inverted
- Wide voltage range: 4V to 24V
- Reverse battery protection: -28V
- CRC check protection
- High EMC/ESD immunity
- Wide operating temperature range:
  - -40°C to 150°C
- Integrated cap+ TVS (PCB-less)
- Package:
  - 3-pin TO-92S (UA)
  - 3-pin TO-92S (PCB-less)
  - 3-pin SOT23-3L (SO)

## 2. Applications

- Automotive and industrial applications
- Seat position detection
- Seat belt detection
- Protective cover / Luggage case / Door lock storage switch
- Window anti-pinch control
- Wiper motor switch

## 3. Description

SC2589X is manufactured using BCD technology and is a two-wire current-mode output programmable automotive-grade Hall effect sensor. It is developed in accordance with the ISO 26262 standard and supports the ASIL B functional safety level. Programmable is a key attribute of the SC2589X. Customer can select pre-programmed units, or program at end of line to realize the system optimization across a range spanning -22mT to 22mT. And the low current state supports programming of 3.3mA and 6mA. SC2589X is specifically designed according to the requirements of automotive applications, complies with the AEC-Q100 standard, supports operation with voltages ranging from 4V to 24V, It has a functional safety function, which outputs a safe current in abnormal situations, and is equipped with a -28V reverse voltage protection function.

SC2589X device is available in either a TO-92S package (UA) and SOT23-3L package (SO).and provides options for capacitors and Transient Voltage Suppressor diodes (PCB-less) integrated in the TO-92S package (UA). All are lead (Pb) free, with 100% matte tin lead frame plating.



Fig.1 Package Outline

## CONTENTS

<b>1. Features</b> .....	<b>1</b>	<b>10. Block Diagram</b> .....	<b>9</b>
<b>2. Applications</b> .....	<b>1</b>	<b>11. Function Description</b> .....	<b>10</b>
<b>3. Description</b> .....	<b>1</b>	<b>11.1. Magnetic Field Direction Definition</b> .....	<b>10</b>
<b>4. Terminal Configuration</b> .....	<b>4</b>	<b>11.2. Transfer Function</b> .....	<b>11</b>
<b>5. Ordering Information</b> .....	<b>5</b>	<b>11.3. Diagnostic Features</b> .....	<b>12</b>
<b>6. Absolute Maximum Ratings</b> .....	<b>6</b>	<b>12. Typical Application</b> .....	<b>12</b>
<b>7. ESD Protection</b> .....	<b>6</b>	<b>13. Package Information UA</b> .....	<b>13</b>
<b>8. Thermal Characteristics</b> .....	<b>6</b>	<b>14. Package Information SO</b> .....	<b>14</b>
<b>9. Operating Characteristics</b> .....	<b>7</b>	<b>15. TAPE AND REEL INFORMATION</b> .....	<b>15</b>
<b>9.1. Electrical Characteristics</b> .....	<b>7</b>	<b>16. TAPE AND REEL BOX DIMENSIONS</b> .....	<b>17</b>
<b>9.2. Magnetic Characteristics</b> .....	<b>8</b>	<b>17. Revision History</b> .....	<b>18</b>
<b>9.3. Program Related Specification</b> .....	<b>9</b>		

### 4. Terminal Configuration

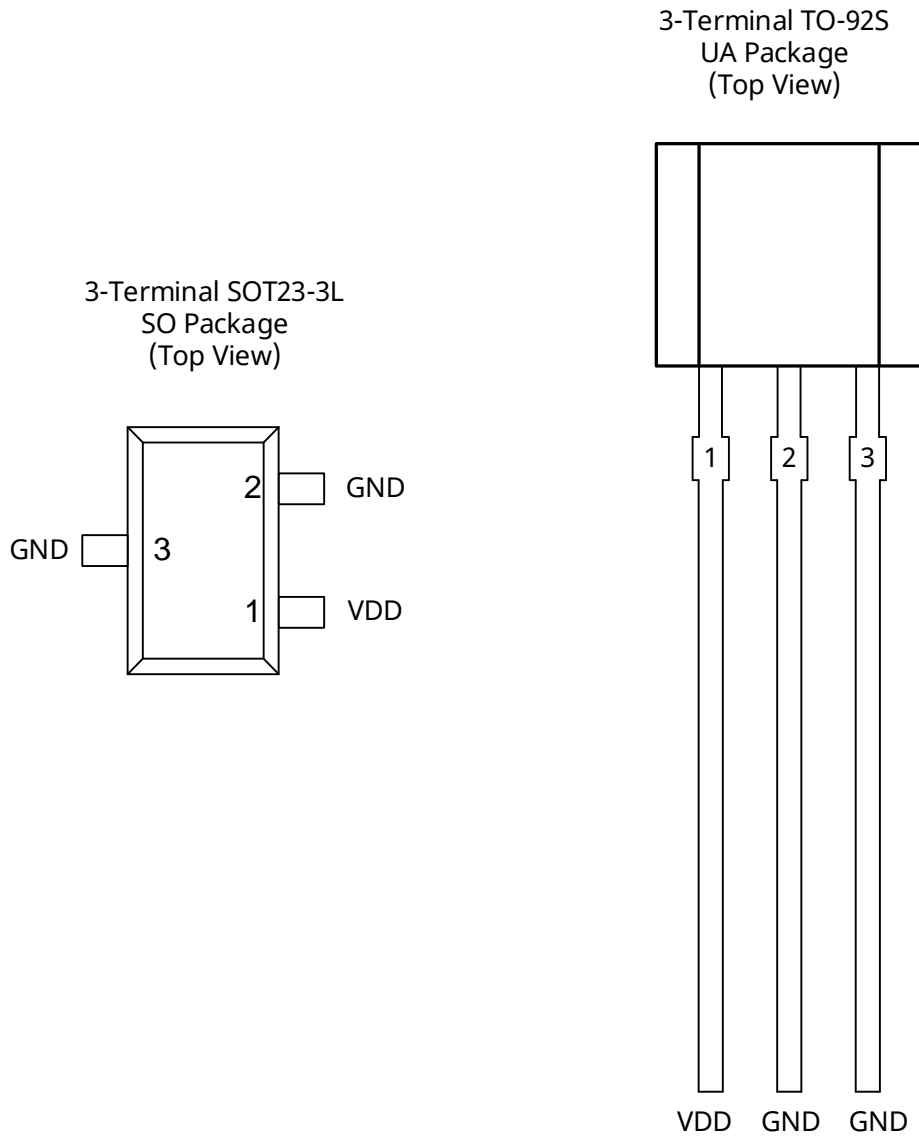

Fig.2 Pin Definition Diagram

Terminal			Type	Description
Name	SO	UA		
VDD	1	1	Power	4V to 24V power supply
GND	2	2	Ground	Ground terminal
GND	3	3	Ground	Ground terminal

## 5. Ordering Information

Ordering Information	Marking	I <sub>DDL</sub> (mA)	I <sub>DDH</sub> (mA)	B <sub>OP</sub> (mT)	B <sub>RP</sub> (mT)	Package	Packing	Quantity
SC25892SO-TR-Q	25892	6	14	8.6	7.6	SOT23-3L	Reel	3000/reel
SC25892UA-BK-Q	25892	6	14	8.6	7.6	TO-92S	Bulk	1000/bag
SC25893SO-TR-Q	25893	6	14	8.7	7.3	SOT23-3L	Reel	3000/reel
SC25893TUA-TR-Q	25893T	6	14	8.7	7.3	TO-92S	Reel	2000/reel
SC25893SO-L-TR-Q	25893	3.3	14	8.7	7.3	SOT23-3L	Reel	3000/reel
SC25893UA-L-BK-Q	25893	3.3	14	8.7	7.3	TO-92S	Bulk	1000/bag
SC25894SO-TR-Q	25894	6	14	9.2	7.2	SOT23-3L	Reel	3000/reel
SC25894UA-BK-Q	25894	6	14	9.2	7.2	TO-92S	Bulk	1000/bag
SC25894SO-L-TR-Q	25894	3.3	14	9.2	7.2	SOT23-3L	Reel	3000/reel
SC25894UA-L-BK-Q	25894	3.3	14	9.2	7.2	TO-92S	Bulk	1000/bag
SC25895SO-TR-Q	25895	6	14	12.2	10.9	SOT23-3L	Reel	3000/reel
SC25895UA-BK-Q	25895	6	14	12.2	10.9	TO-92S	Bulk	1000/bag
SC25899SO-TR-Q	25899	PROG	PROG	PROG	PROG	SOT23-3L	Reel	3000/reel
SC25899UA-BK-Q	25899	PROG	PROG	PROG	PROG	TO-92S	Bulk	1000/bag

### Ordering Information Format

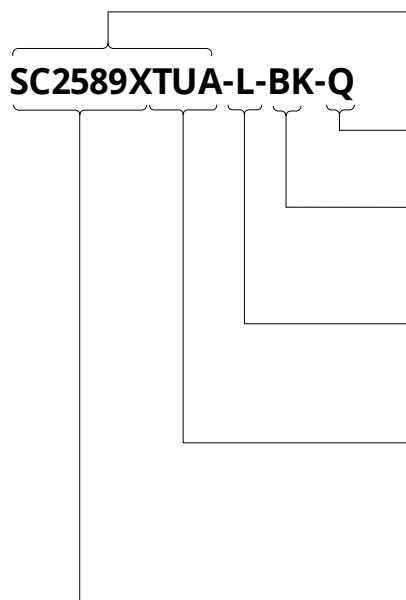

#### Part Number

#### Product Grade

Q: Automotive Product

#### Pack Designation

TR: Tape & Reel

BK: Bulk

#### Function

Blank: 6.0mA/14mA

L: 3.3mA/14mA

#### Package Designation

SE: SOT23-3L

UA: TO-92S

TUA: TO-92S Add cap and TVS(PCB-less )

#### Device Family

SC2589X: Two-Wire Programmable Hall Effect Switches IC

## 6. Absolute Maximum Ratings

over operating free-air temperature range (unless otherwise noted) <sup>(1)</sup>

Symbol	Parameter	Test Conditions	Min.	Max.	Units
V <sub>DD</sub>	Power supply voltage		-28	60	V
V <sub>DD</sub>	Power supply voltage	PCB-less package <sup>(2)</sup>	-28	40	V
I <sub>DD</sub>	Supply current		0	40 <sup>(3)</sup>	mA
I <sub>DD REV</sub>	Reverse supply current		-20	-	mA
T <sub>A</sub>	Operating ambient temperature		-40	150	°C
T <sub>J</sub>	Maximum junction temperature	For 168h max	-40	165	°C
T <sub>STG</sub>	Storage temperature		-65	175	°C

Note:

(1) Stresses above those listed here may cause permanent damage to the device. Exposure to absolute maximum rating conditions for extended periods may affect device reliability

(2) PCB-less package integrated 40V TVS

(3) For maximum 500ms

## 7. ESD Protection

Symbol	Parameter	Test Conditions	Min.	Max.	Units
V <sub>ESD_HBM</sub>	HBM	According to: standard AEC-Q100-002 HBM	-8	+8	kV
V <sub>ESD_HBM</sub>	HBM(PCB-less)	According to: standard AEC-Q100-002 HBM	-15	+15	kV
V <sub>ESD_CDM</sub>	CDM	According to: standard AEC-Q100-011 CDM	-2	+2	kV

## 8. Thermal Characteristics

Symbol	Parameter	Test Conditions	Rating	Units
R <sub>θja</sub>	UA Package thermal resistance	Single-layer PCB, with copper limited to solder pads	200 <sup>(1)</sup>	°C/W
R <sub>θja</sub>	SO Package thermal resistance	Single-layer PCB, with copper limited to solder pads	300 <sup>(1)</sup>	°C/W

Note:

(1) Maximum voltage must be adjusted for power dissipation and junction temperature, see Thermal Characteristics

## 9. Operating Characteristics

### 9.1. Electrical Characteristics

over operating free-air temperature range  $V_{DD}=12V$  (unless otherwise noted)

Symbol	Parameter	Test Conditions	Min.	Typ. <sup>(1)</sup>	Max.	Units
$V_{DD}$	Operating voltage	$T_J < T_{J(Max)}$	4.0	12	24	V
$I_{DDL}$	Operating supply current	$V_{DD}= 3.0$ to 24V	2.0	3.3	5.0	mA
			5.0	6.0	6.9	mA
$I_{DDH}$	Operating supply current	$V_{DD}= 3.0$ to 24V	12	14	17	mA
$I_{Rev}$	Reverse Supply current	$V_{DD}= -24V$	-1	-	-	mA
$I_{SAFE}$	Safe Mode Supply Current		-	1.0	1.5	mA
UVLO <sub>H</sub>	Under Voltage Lockout High	$B > B_{OP}$ , $V_{DD}$ Rising From 2V	-	1.95	-	V
UVLO <sub>L</sub>	Under Voltage Lockout Low	$B > B_{OP}$ , $V_{DD}$ Decreasing From 4V	-	1.85	-	V
UVLO <sub>HYS</sub>	Under Voltage Hysteresis	UVLO <sub>H</sub> - UVLO <sub>L</sub>	-	100	-	mV
$t_{ON}$	Power on time	$V_{DD}= 5.0V$	-	170	300	$\mu s$
$t_d$	Output delay time	$V_{DD} = 12V$ , $R_{sense}=100\Omega$ , $C_{BYP}=100nF$	-	-	25	$\mu s$
Sr	Output Slew Rate	$V_{DD} = 12V$ , $R_{sense}=100\Omega$ , $C_{BYP}=100nF$	1.0	3.0	5.0	$\mu s$
$F_{SW}$	Maximum switching frequency		10	-	-	kHz
$C_{intg}$	Integrated bypass capacitor		-	100	-	nF
TVS <sub>intg</sub>	Integrated TVS BV voltage		-	40	-	V

Note:

(1) Typical values are defined at  $T_A = +25^\circ C$  and  $V_{DD} = 12V$

(2) Maximum voltage must be adjusted for power dissipation and junction temperature, see Thermal Characteristics

## 9.2. Magnetic Characteristics

over operating free-air temperature range,  $V_{DD} = 12V$  (unless otherwise noted)

Symbol	Parameter	Test Conditions	Min.	Typ.	Max.	Units
<b>SC25892 8.6<sup>(1)</sup>/7.6mT<sup>(2)</sup></b>						
$B_{OP}$	Operating point	$T_A=25^\circ C$	7.1	8.6	10.1	mT
$B_{RP}$	Release point		6.0	7.6	9.2	mT
$B_{HYS}$	Hysteresis		-	1.0	-	mT
<b>SC25893 8.7/7.3mT</b>						
$B_{OP}$	Operating point	$T_A=25^\circ C$	7.2	8.7	10.3	mT
$B_{RP}$	Release point		5.7	7.3	9.0	mT
$B_{HYS}$	Hysteresis		-	1.4	-	mT
<b>SC25894 9.2/7.2mT</b>						
$B_{OP}$	Operating point	$T_A=25^\circ C$	6.0	9.2	12.0	mT
$B_{RP}$	Release point		5.0	7.2	10.5	mT
$B_{HYS}$	Hysteresis		-	2.0	-	mT
<b>SC25895 12.2/10.9mT</b>						
$B_{OP}$	Operating point	$T_A=25^\circ C$	10.4	12.2	14.0	mT
$B_{RP}$	Release point		9.0	10.9	12.8	mT
$B_{HYS}$	Hysteresis		-	1.3	-	mT
<b>SC25899 Programmable Sensitivity</b>						
$B_{OP}$	Operating point	$T_A=25^\circ C$	-22	-	22	mT
$B_{HYS}$	Hysteresis		0.5	-	10	mT
$B_{OP(STEP)}^{(3)}$	Average Magnetic Step Size		0.3	0.5	0.7	mT
$B_{HYS(STEP)}^{(4)}$	Average Hysteresis Step Size		0.3	0.5	0.7	mT
$B_{OP(INT)}$	Initial Operation Point		6	8.2	10	mT
$B_{HYS(INT)}$	Initial Hysteresis		1	2	3.5	mT

Note:

(1) Magnetic flux density,  $B$  is indicated as a negative value for North-polarity magnetic fields, and as a positive value for South-polarity magnetic fields

(2)  $1mT=10Gs$

(3)  $B_{OP(STEP)}$  is a calculated average from the cumulative programmed bits

(4)  $B_{HYS(STEP)}$  is a calculated average from the cumulative programmed bits

### 9.3. Program Related Specification

$V_{DD} = 12.0V$ ,  $T_A = -40^{\circ}C$  to  $150^{\circ}C$  (unless otherwise noted)

Symbol	Parameter	Test Conditions	Min.	Typ.	Max.	Units
BOPSEL	Operation Point Magnitude Programming		-	6	-	BIT
HYSSEL	Magnitude Hysteresis Programming		-	6	-	BIT
MAG_POL	Magnetic Polarity Selection	The default value is 0.	-	1	-	BIT
OMNI	Unipolar/Omnipolar/Latch Selection	The default value is 0.	-	1	-	BIT
LTH	Unipolar/Omnipolar/Latch Selection	The default value is 0.	-	1	-	BIT
OUT_POL	Output Polarity Selection	The default value is 0.	-	1	-	BIT
IDDL	Low current level selection	The default value is 1.	-	1	-	BIT

## 10. Block Diagram

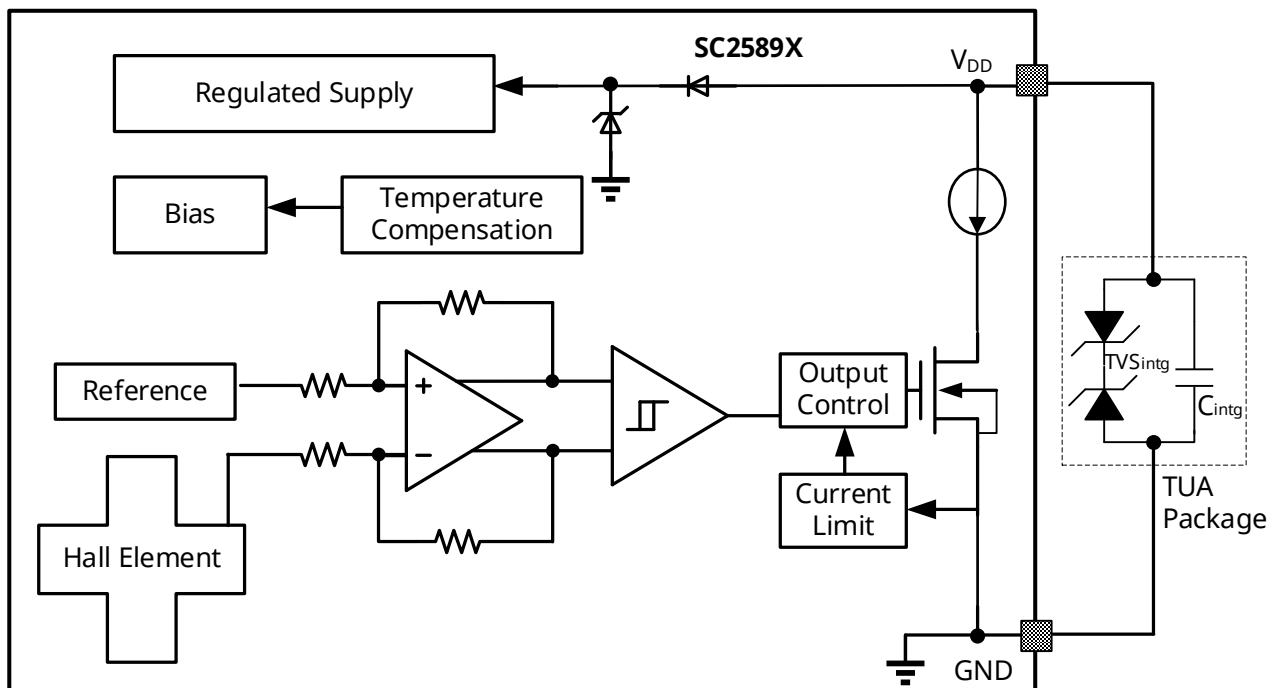

Comments: Only TO-92 TUA Package integrated a capacitor and a TVS between  $V_{DD}$  and GND

Fig. 3 Functional block diagram

## 11. Function Description

The SC2589X device is a two-wire current-mode programmable Hall effect sensor that provides an indication when the magnetic flux density exceeds a threshold. Programming can be performed at the end of the line to optimize the sensor on a per unit or per module basis. The user can select the magnetic operating points across a range spanning -22 mT to 22 mT, the magnitude hysteresis across a range spanning 0.5 mT to 10 mT, and whether the device responds to north or south magnetic fields (unipolar switch) or both (omnipolar switch), and output polarity (direct or inverted). In addition, the low current state supports programming at 3.3 mA and 6 mA.

The output of SC2589X switches  $I_{DD}$  is  $I_{Low}$ , when a magnetic field (South polarity) perpendicular to the Hall element exceeds the operating point threshold,  $B_{OP}$ . When the magnetic field is reduced below the release point,  $B_{RP}$ , the device  $I_{DD}$  is  $I_{High}$ . The difference in the magnetic operation and release points is the hysteresis,  $B_{HYS}$ , of the device. This built-in hysteresis allows clean switching of the output even in the presence of external mechanical vibration and electrical noise.

### 11.1. Magnetic Field Direction Definition

A positive magnetic field is defined as the magnetic South pole facing the marked side of the package.

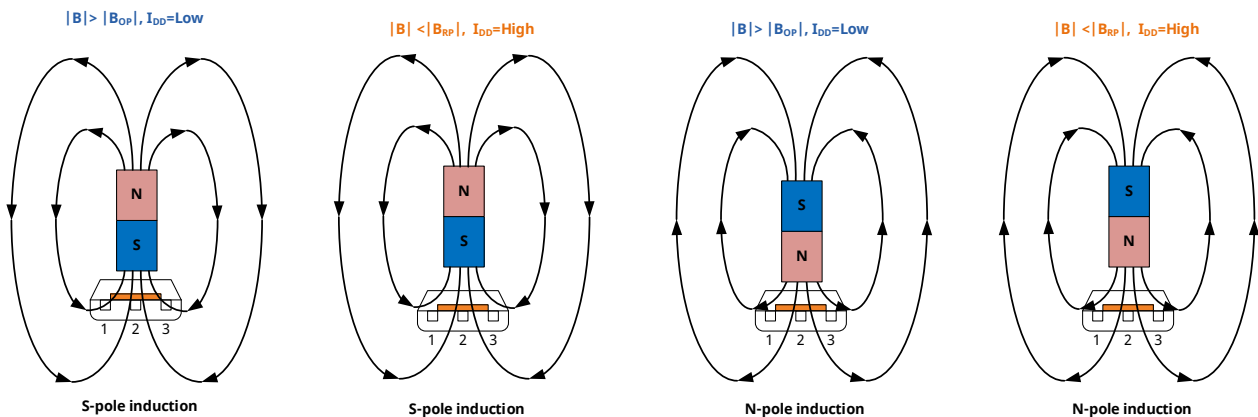

Fig.4 Magnetic Field Direction Definition

### 11.2. Transfer Function

“Omnipolar” magnetic characteristics, it means the device reacts to both North and South magnetic pole. The purpose is to detect the presence of any magnetic field applied on the device.

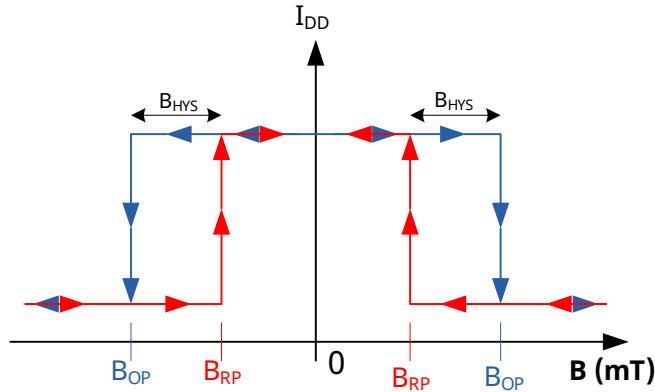

Fig.5 Omnipolar Transfer Function diagram

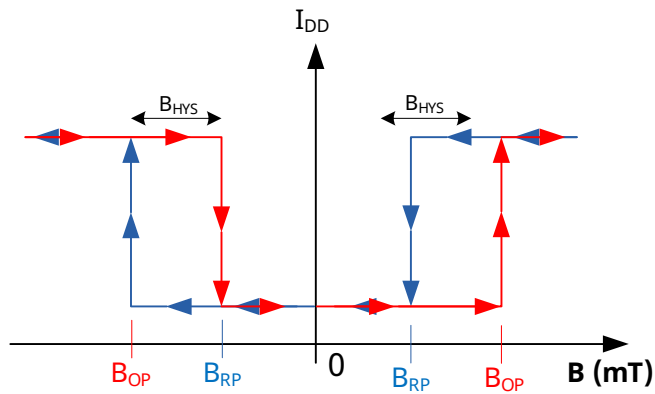

Fig.6 Omnipolar and Unipolar Inverted output Transfer Function diagram

“Unipolar” magnetic characteristics, it means the device only reacts to North or South magnetic pole.

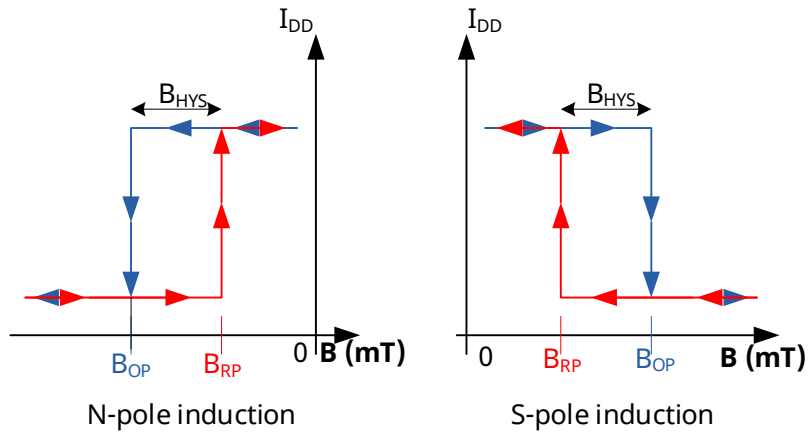

Fig.7 Unipolar Transfer Function diagram

### 11.3. Diagnostic Features

When the SC2589X is powered normally, the operating current has only two states:  $I_{DDH}$  or  $I_{DDL}$ . Any state with a current value outside this range can be regarded as a fault condition. In the event of a short circuit, the operating current will exceed  $I_{DDH}$ ; in the event of an open circuit, the operating current will be lower than  $I_{DDL}$ . In this way, the connection status between the ECU and the sensor can be easily detected

## 12. Typical Application

It is strongly recommended that an external bypass capacitor,  $C_{BYP}$ , be connected (in close proximity to the Hall sensor) between the supply and ground of the device to guarantee correct performance under harsh environmental conditions and to reduce noise from internal circuitry. As is shown in Figure Below, a  $0.01\ \mu\text{F}$  capacitor is typical. Use of a larger bypass capacitor may result in a slower output slew rate and should be evaluated according to the requirements set forth by the application. Additionally, an optional output load capacitor may be added in parallel with the sense resistor for increased signal filtering and EMC immunity.

In addition, when using TUA packaging, since the TUA packaging chip already integrates a capacitor and a TVS diode internally, the external  $C_{BYP}$  capacitor can be omitted when designing the overall sensor scheme, thus achieving a PCB-less solution without PCBA requirements.

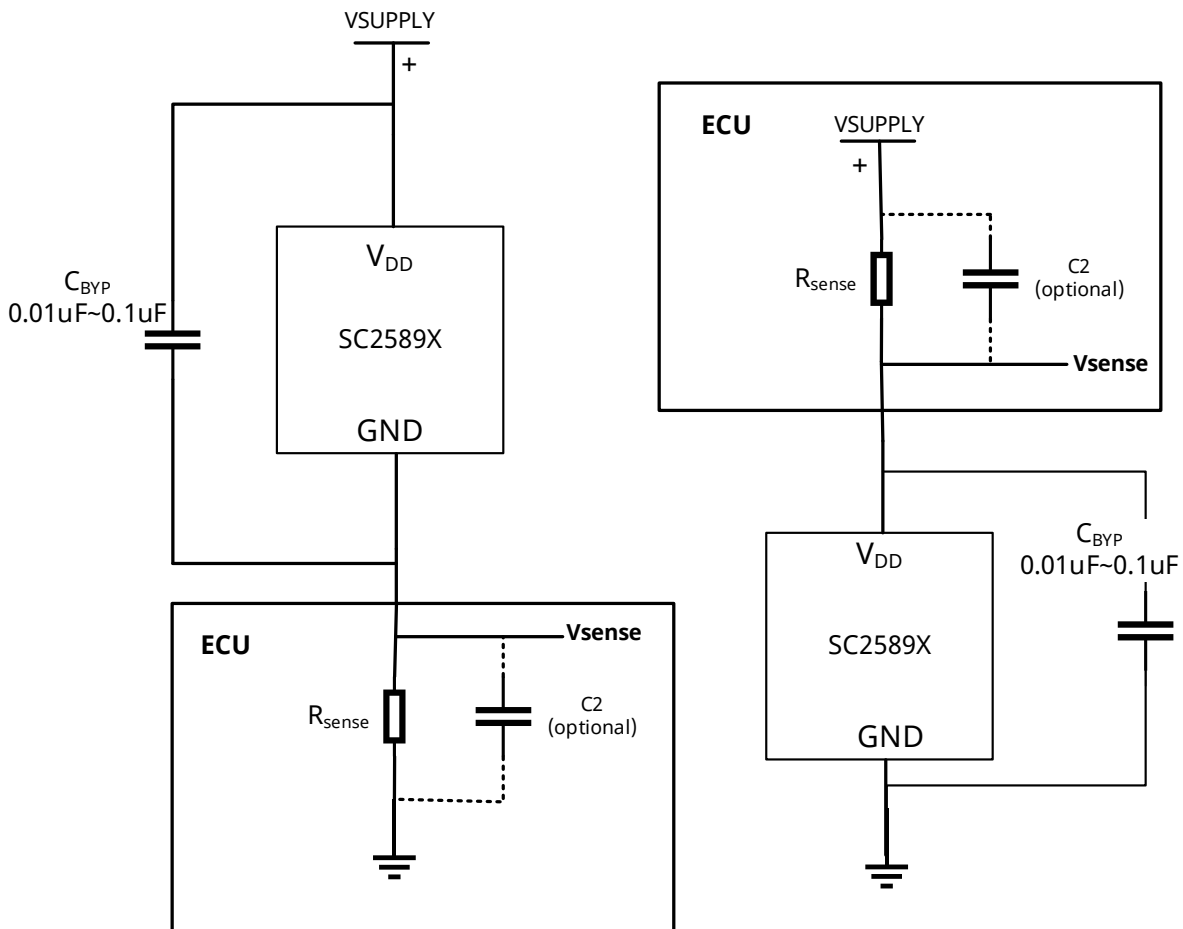
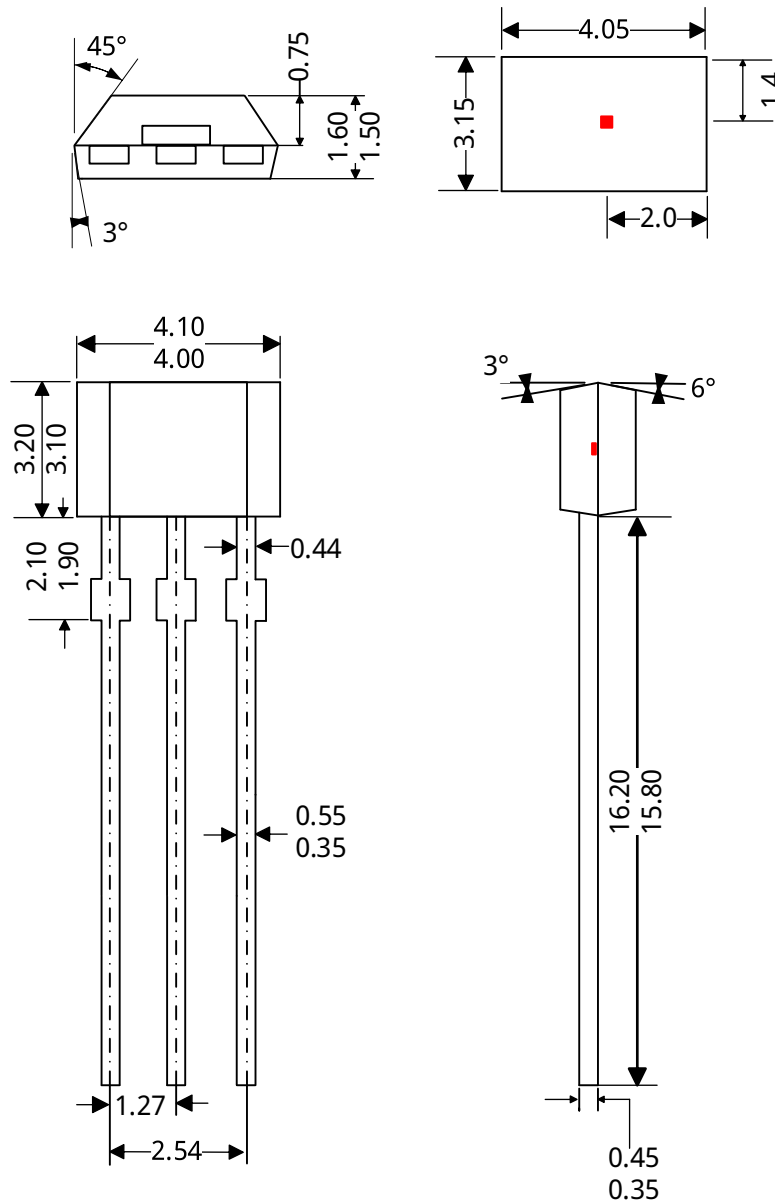

Fig.8 SC2589X Typical Application Circuit

## 13. Package Information UA

### TO-92S-S2 PACKAGE OUTLINE DIMENSIONS



**Notes:**

- (1) All unit in mm.
- (2) Dimension does not include mold flash, protrusions or gate burrs.
- (3) Allowable dambar protrusion shall be in excess at maximum material condition.

If no tolerance is specified, the dimension shall be theoretical reference value and shall not represent the exact dimension for actual measurement.

## 14. Package Information SO

3-Terminal SO Package

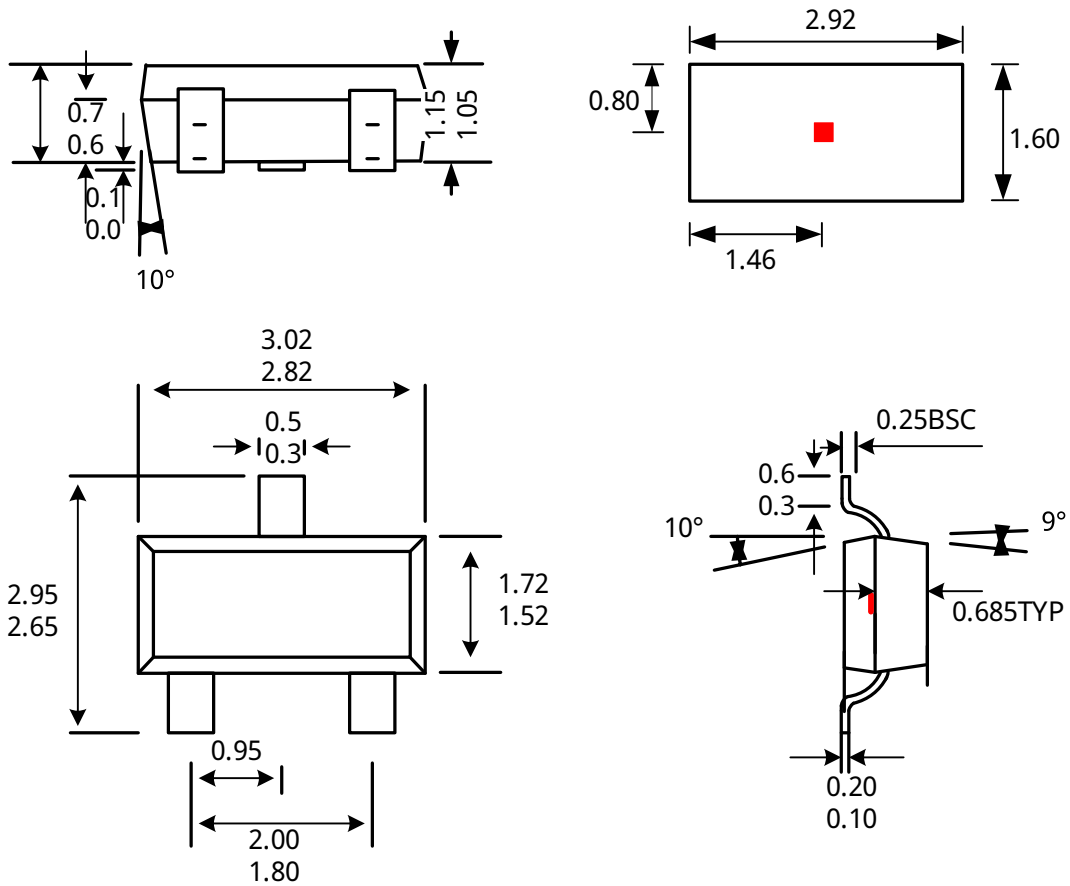

**Notes:**

- (1) All unit in mm.
- (2) Dimension does not include mold flash, protrusions or gate burrs.
- (3) Allowable dambar protrusion shall be in excess at maximum material condition.

If no tolerance is specified, the dimension shall be theoretical reference value and shall not represent the exact dimension for actual measurement.

## 15. TAPE AND REEL INFORMATION

TAPE REEL DIMENSIONS

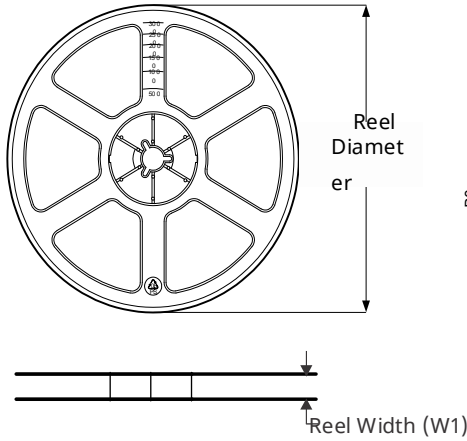

TAPE DIMENSIONS

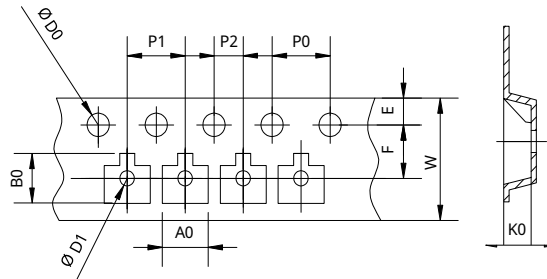

QUADRANT ASSIGNMENTS FOR PIN 1 ORIENTATION IN TAPE

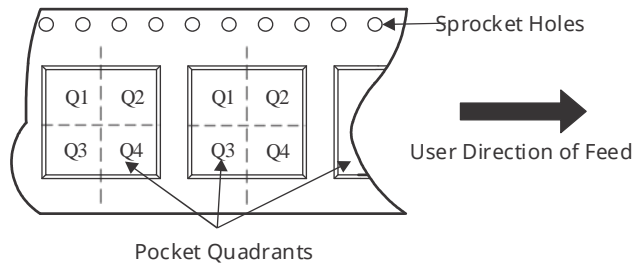

\*All dimensions are nominal

Package Type	SPQ	Reel Diameter (mm)	Reel Width W1 (mm)	P0 (mm)	P1 (mm)	P2 (mm)	A0 (mm)	B0 (mm)	K0 (mm)	W (mm)	Pin1 Quadrant
SOT-23-3L	3000	180	8.4	4.00	2.00	4.00	3.18	3.28	1.32	8.00	Q3



## 16. TAPE AND REEL BOX DIMENSIONS

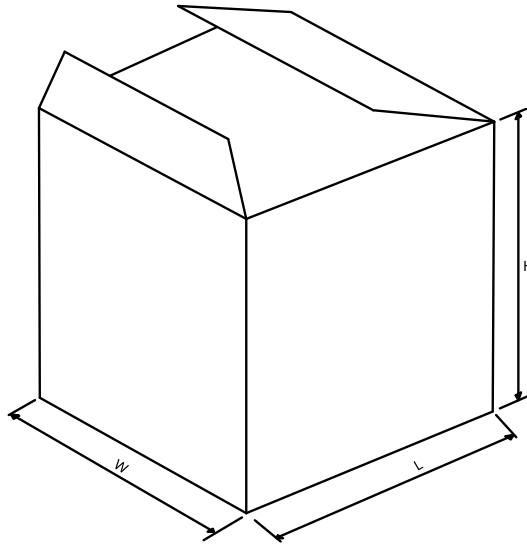

\*All dimensions are nominal

Package Type	SPQ	Length (mm)	Width (mm)	Height (mm)
SOT-23-3L	3000ea*10tape	210	210	210

## 17. Revision History

Revision	Date	Description
Rev.E0.1	2025-03-10	Preliminary Datasheet
Rev.A1.0	2025-07-18	Official version release

## Notice and Disclaimer

The information, data, and specifications set out in this document (the "Document") are provided "AS IS" and for reference purposes, they shall not be construed as any warranty or authorization, whether express or implied, including but not limited to warranties of accuracy, completeness, merchantability, fitness for a particular purpose, or non-infringement of any third party's intellectual property rights.

Users of this Document are solely responsible for the selection, use, and application of SEMIMENT products, as well as for ensuring the safety of such applications. Users shall comply with all applicable laws, regulations, and requirements related to the use of SEMIMENT products. Any application-related information or support that may be provided by SEMIMENT is for reference only and does not constitute any guarantee or liability.

The resources described in this Document are subject to change without notice. SEMIMENT grants permission to use these resources solely for the development of applications incorporating SEMIMENT products as described herein. Any other reproduction, distribution, or public display of these resources is prohibited without prior written consent. No license, express or implied, is granted under any SEMIMENT intellectual property rights or any third-party intellectual property rights.

You agree to defend, indemnify and hold harmless SEMIMENT and its representatives from and against any claims, damages, costs, losses, or liabilities arising from your use of these resources.

For the latest product information and technical support, please contact SEMIMENT ([www.semiment.com](http://www.semiment.com)).

**Copyright © Semiment Technology Co.,Ltd**