

## Two-wire current-mode latched Hall effect switch IC

### 1. Features

- AEC-Q100 qualified
- ISO26262 ASIL B
- Two-wire current-type output interfacer
  - 2-wire output interface
  - Interconnect open/short diagnostics
- Up to 1MHz high chopping frequency
- Wide voltage range: 4V to 24V
- Reverse battery protection: -28V
- Wide operating temperature range:
  - -40°C to 150°C
- Thermal shutdown protection
- High EMC/ESD immunity
- Multiple packaging forms are available
  - 3 pin TO92S(UA)
  - 2 pin TO92S(CUB)-Integrate a 100nF capacitor

### 2. Applications

- Automotive and industrial safety system
- Seat Position detection
- Seat belt buckles
- Door latch switch
- Wiper motor switch Wiper motors

### 3. Description

The SC25898 family, designed and produced on high voltage BCD process, is a chopper-stabilized 2-wire Hall Effect Sensor with current interface that offers a magnetic sensing solution with superior sensitivity stability over temperature and integrated protection features.

The internal voltage regulator circuit of the chip can withstand a working voltage input voltage range of 4 to 24V, which is suitable for application in the industrial and automotive fields. At the same time, it makes the chip have strong electromagnetic interference (EMC) resistance and high reliability.

SC25898 adopts dynamic misalignment elimination and temperature compensation technology to reduce misalignment caused by process changes, packaging, and temperature stress, and has stable sensitivity. Internally integrated circuit modules include voltage stabilization module, Hall array, amplification circuit, low-pass filter, hysteresis comparator, and output current control.

This device is available in 3-pin TO-92S package (UA), and 2-pin TO-92S package (CUB). The 2-wire current-type interface not only saves wires but also facilitates open and short circuit diagnosis.

All packages use 100% lead-free matte tin-plated lead packages.



Fig.1 Package Outline

## CONTENTS

<b>1. Features</b> .....	<b>1</b>	<b>10. Typical Characteristics</b> .....	<b>8</b>
<b>2. Applications</b> .....	<b>1</b>	<b>11. Block Diagram</b> .....	<b>9</b>
<b>3. Description</b> .....	<b>1</b>	<b>12. Function Description</b> .....	<b>9</b>
<b>4. Terminal Configuration</b> .....	<b>3</b>	<b>12.1 Magnetic Field Direction Definition</b> .....	<b>10</b>
<b>5. Ordering Information</b> .....	<b>4</b>	<b>12.2 Transfer Function</b> .....	<b>10</b>
<b>6. Absolute Maximum Ratings</b> .....	<b>5</b>	<b>12.3. Diagnostic Features</b> .....	<b>11</b>
<b>7. ESD Protection</b> .....	<b>5</b>	<b>13. Typical Application</b> .....	<b>11</b>
<b>8. Thermal Characteristics</b> .....	<b>5</b>	<b>14. Package Information UA</b> .....	<b>12</b>
<b>9. Operating Characteristics</b> .....	<b>6</b>	<b>15. Package Information CUB</b> .....	<b>13</b>
<b>9.1. Electrical Characteristics</b> .....	<b>6</b>	<b>16. Revision History</b> .....	<b>14</b>
<b>9.2. Magnetic Characteristics</b> .....	<b>7</b>		

### 4. Terminal Configuration

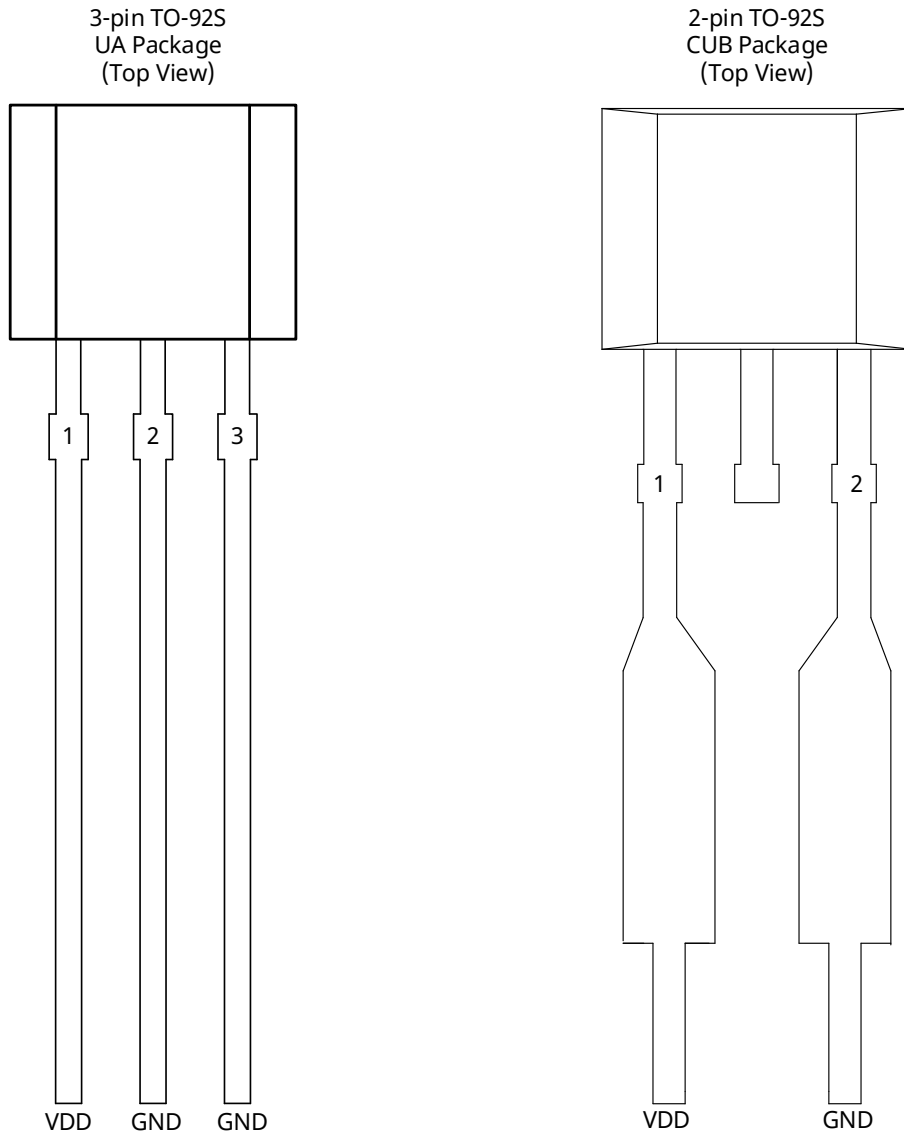

Fig.2 Terminal Configuration Definition

Terminal			Type	Description
Name	UA	CUB		
VDD	1	1	Power	4V to 24V Power Supply
GND	2	2	Ground	Ground Terminal
GND	3	-	Ground	Ground Terminal

## 5. Ordering Information

Ordering Information	Mark	$I_{DDL}$ (mA)	$I_{DDH}$ (mA)	$B_{OP}$ (mT)	$B_{RP}$ (mT)	Package	Packing	Amount
SC25898UA-BK-Q	25898	4.0	26	-8.0	8.0	TO-92S	Bulk	1000 /bag
SC25898CUB-BK-Q	25898	4.0	26	-8.0	8.0	TO-92S-UB	Bulk	1000 /bag

### Ordering Information Format

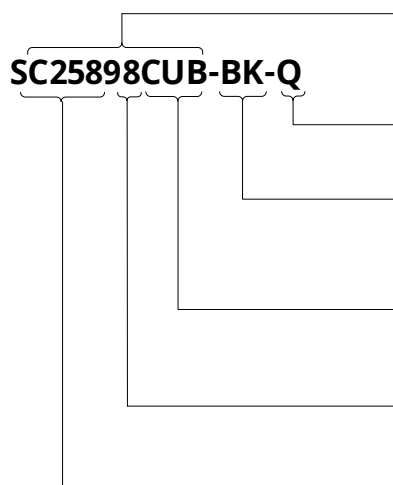

#### Part Number

#### Product Grade

Q: Automotive Product

#### Pack Designation

TR: Tape & Reel

BK: Bulk

#### Package Designation

UA: TO-92S

CUB: TO-92S-UB, integrated with a 100nF capacitor

#### Magnetic Parameter

8:  $B_{OP}$ : -80Gs,  $B_{RP}$ : 80Gs

#### Device Family

SC25898: Two-wire current-mode latched Hall effect switch IC

## 6. Absolute Maximum Ratings

Within the operating temperature range (unless otherwise specified) <sup>(1)</sup>

Symbol	Parameter	Test Conditon	Min.	Max.	Units
V <sub>DD</sub>	Power supply voltage <sup>(2)</sup>	R <sub>s</sub> ≥200Ω, no more than 5 minutes	-28	60	V
I <sub>DDR</sub>	Reverse Supply Current		-1	-	mA
T <sub>A</sub>	Operating ambient temperature		-40	150 <sup>(2)</sup>	°C
T <sub>J</sub>	Maximum junction temperature	No more than 168 hours	-55	165	°C
T <sub>STG</sub>	Storage temperature		-65	175	°C

Note:

(1) Stresses above those listed here may cause permanent damage to the device. Exposure to absolute maximum rating conditions for extended periods may affect device reliability

(2) Maximum voltage must be adjusted for power dissipation and junction temperature, see Thermal Characteristics

## 7. ESD Protection

Symbol	Parameter	Test Condition	Min.	Max.	Units
V <sub>ESD_HBM</sub>	HBM	According to: standard AEC-Q100-002 HBM	-8	+8	kV
V <sub>ESD_HBM</sub>	CDM	According to: standard AEC-Q100-011 CDM	-750	+750	V

## 8. Thermal Characteristics

Symbol	Parameter	Test Conditions	Rating	Units
R <sub>θJA</sub>	UA/CUB Package thermal resistance	Single-layer PCB, with copper limited to solder pads	200 <sup>(1)</sup>	°C/W

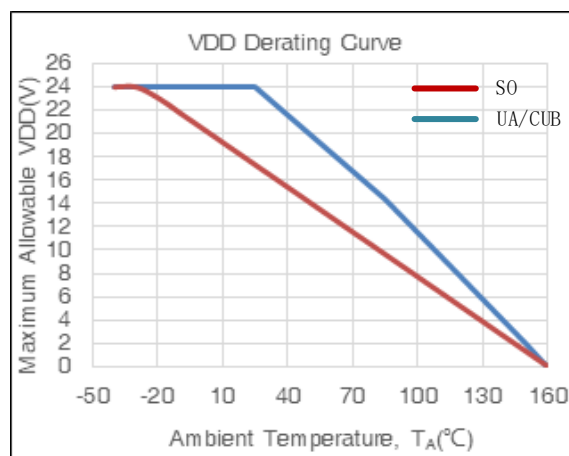

Note:

(1) Maximum voltage must be adjusted for power dissipation and junction temperature, see Thermal Characteristics.

## 9. Operating Characteristics

### 9.1. Electrical Characteristics

Within the operating temperature range,  $V_{DD} = 12\text{ V}$  (unless otherwise specified)

Symbol	Parameter	Test Conditions	Min.	Typ. <sup>(1)</sup>	Max.	Units
$V_{DD}$	Operating Voltage <sup>(2)</sup>	$T_J < T_{J(\text{Max.})}$	4	12	24	V
$V_{DDR}$	Reverse Supply Voltage	$I_{DD} < -10\text{mA}$ , $T_A = 25^\circ\text{C}$	-28	-	-	V
$UVLO_H$	Under Voltage Lockout High	$B > B_{OP} + 2.0\text{mT}$ , $V_{DD}$ Rising From 1.5V	-	1.9	-	V
$UVLO_L$	Under Voltage Lockout Low	$B > B_{OP} + 2.0\text{mT}$ , $V_{DD}$ Decreasing From 2.5V	-	1.7	-	V
$UVLO_{HYS}$	Under Voltage Hysteresis	$UVLO_H - UVLO_L$	-	200	-	mV
$I_{DDL}$	Low Supply Current	$V_{DD} = 4$ to 24 V, $T_A = 25^\circ\text{C}$	-	4	-	mA
$I_{DDH}$	High Supply Current	$V_{DD} = 4$ to 24 V, $T_A = 25^\circ\text{C}$	-	26	-	mA
OTP	Over Temperature Protection	Temperature increasing	-	187	-	$^\circ\text{C}$
$OTP_{HYS}$	Over Temperature Hysteresis		-	13	-	$^\circ\text{C}$
$t_{on}$	Power-on time	$V_{DD} > 2.5\text{V}$	-	50	60	$\mu\text{s}$
$t_d$	Output delay time	$B = B_{RP}$ to $B_{OP}$	-	15	40	$\mu\text{s}$

Note:

(1) Typical values are defined at  $T_A = +25^\circ\text{C}$  and  $V_{DD} = 12\text{V}$

(2) The maximum operating voltage must meet the requirements of power consumption and junction temperature, See Thermal Characteristics

## 9.2. Magnetic Characteristics

Within the operating temperature range,  $V_{DD} = 12\text{ V}$  (unless otherwise specified)

Symbol	Parameter	Test Conditions	Min.	Typ.	Max.	Units
$f_{BW}$	Bandwidth		20			kHz
<b>SC25898UA/CUB -8.0 / 8.0 mT</b>						
$B_{OP}$	Operated point	$T_A=25^\circ\text{C}$	-10.0	-8.0	-6.0	mT
$B_{RP}$	Release point		6.0	8.0	10.0	mT
$B_{HYS}$	Hysteresis		12.0	16.0	20.0	mT
$B_O$	Magnetic offset	$B_O=(B_{OP}+B_{RP})/2$	-2.0	0	2.0	mT

**Note:**

(1)  $1\text{ mT}=10\text{Gs}$

(2) Magnetic flux density,  $B$  is indicated as a negative value for North-polarity magnetic fields, and as a positive value for South-polarity magnetic fields

### 10. Typical Characteristics

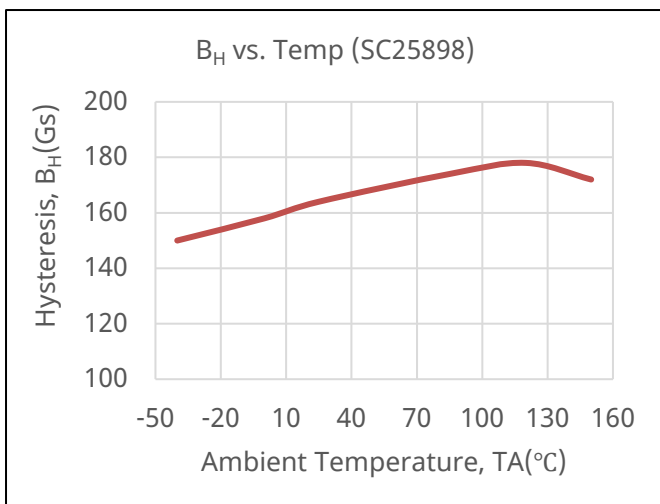
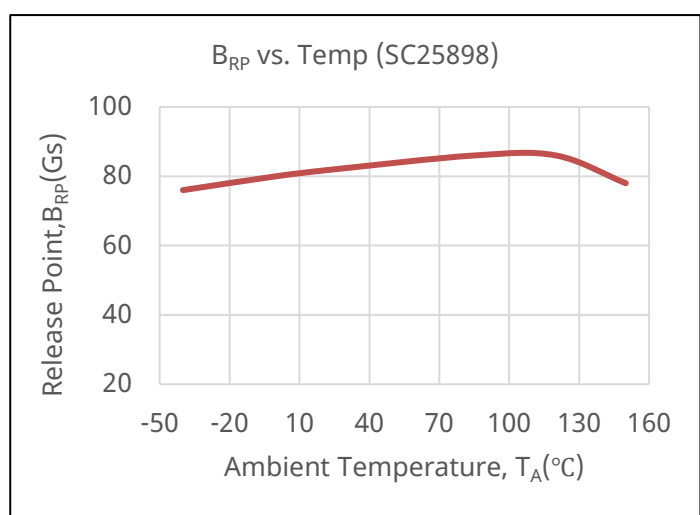
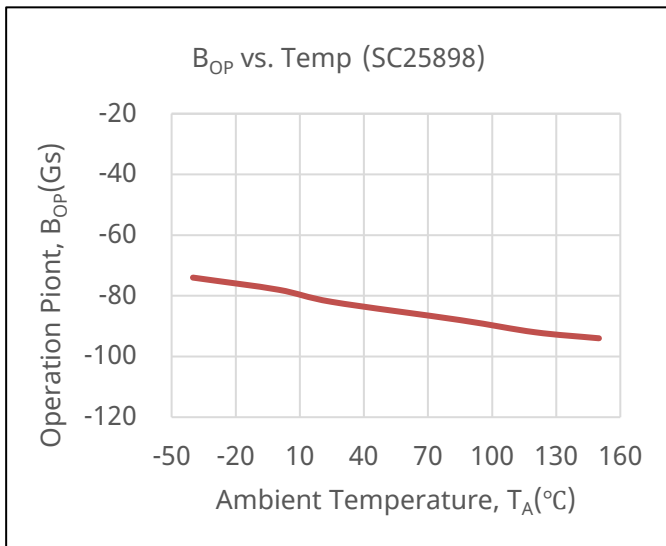
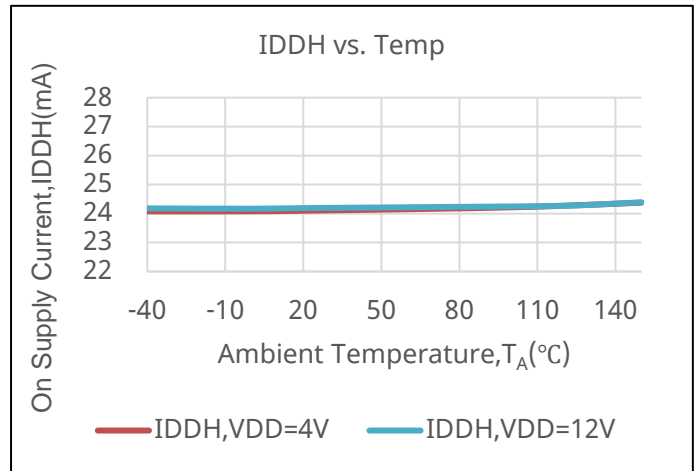
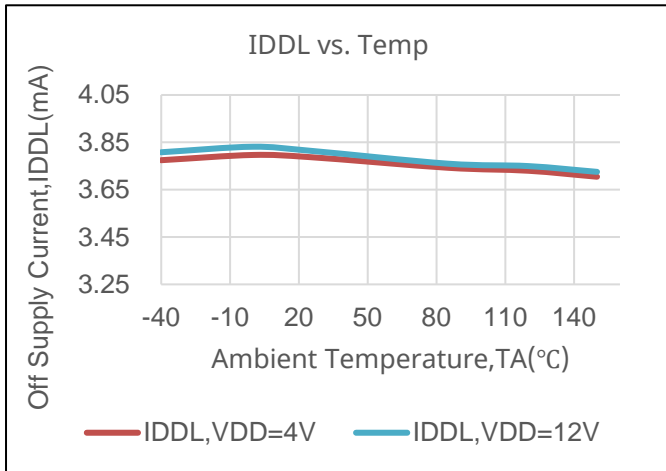

## 11. Block Diagram

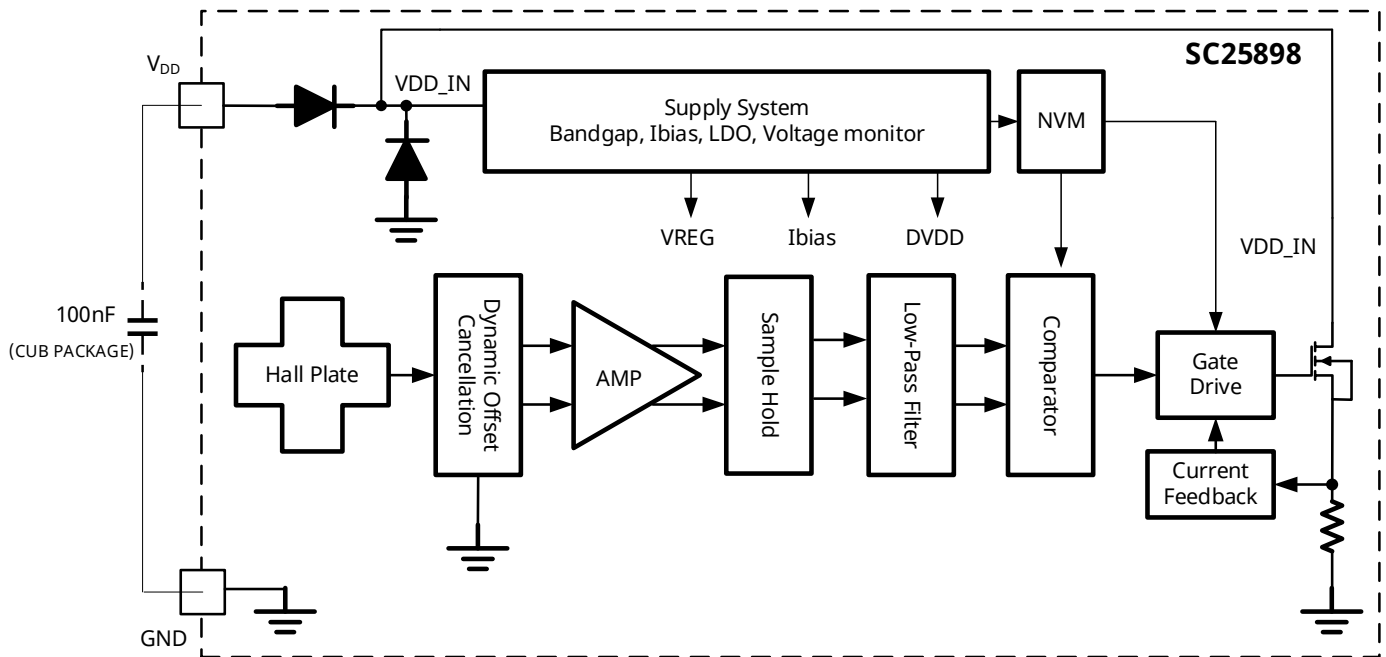

Fig.3 Function Block Diagram

## 12. Function Description

The SC25898 device is a chopper-stabilized 2-wire Hall sensor with current interface output for magnetic sensing applications. The device can be powered with a supply voltage between 4V to 24V, and continuously survives continuous -28V reverse-battery conditions.

The output of SC25898 series switches to  $I_{DDH}$  (turns on) when the absolute value of a magnetic field perpendicular to the Hall element exceeds the absolute value of the operate point threshold,  $B_{OP}$ . When the magnetic field is reduced below the absolute value of the release point,  $B_{RP}$ , the supply current of the device goes  $I_{DDL}$  (turns off). The difference between the magnetic operate and release points is the hysteresis,  $B_{HYS}$ , of the device. This built-in hysteresis allows clean switching of the output even in the presence of external mechanical vibration and electrical noise.

### 12.1 Magnetic Field Direction Definition

A positive magnetic field is defined as a South pole near the marked side of the package.

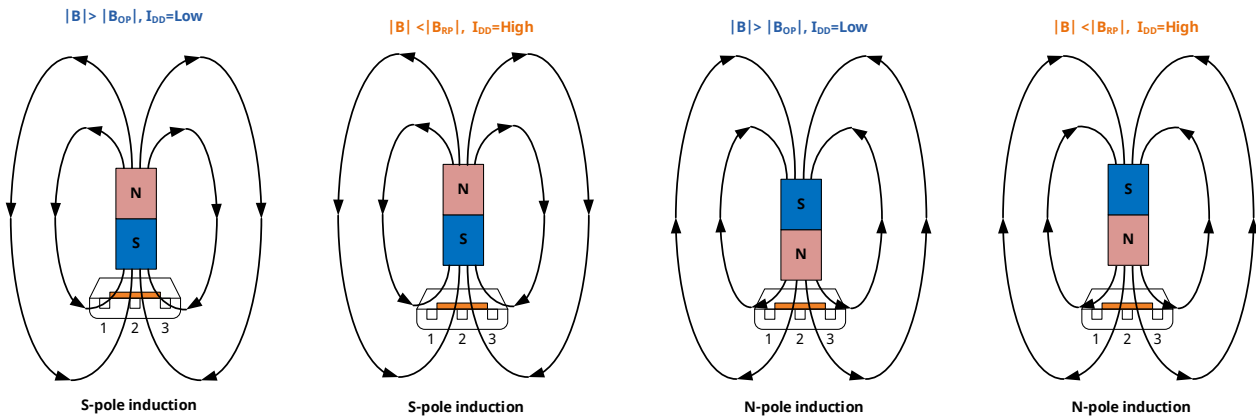

Fig.4 Magnetic Field Direction Definition

### 12.2 Transfer Function

Powering-on the device in the hysteresis region, less than  $B_{OP}$  and higher than  $B_{RP}$ , allows an indeterminate output state. The correct state is attained after the first excursion beyond  $B_{OP}$  or  $B_{RP}$ . If the absolute value of the field strength is greater than the absolute value of  $B_{OP}$ , then the supply current is high ( $I_{DDH}$ ). If the absolute value of the field strength is greater than the absolute value of  $B_{RP}$ , the output is released, the supply current is low ( $I_{DDL}$ ).

$B_{OP}$ —magnetic threshold for activation of the device output, turning in ON state.

$B_{RP}$ —magnetic threshold for release of the device output, turning in OFF state.

$$B_{HYS} = B_{OP} - B_{RP}$$

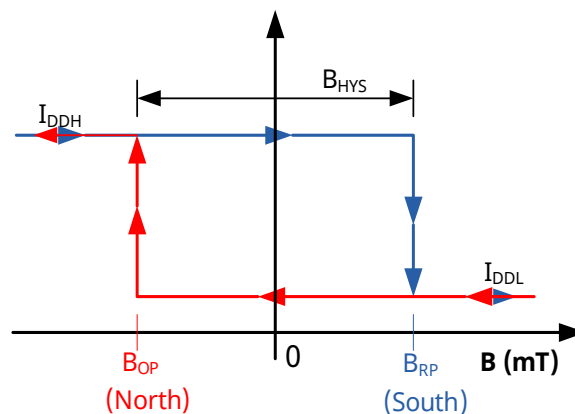

Fig.5 Magnetic Transfer Function

### 12.3. Diagnostic Features

When properly supplied, SC25898 always has current flowing at a specified level: either  $I_{DDH}$  or  $I_{DDL}$ . Any current outside of these narrow ranges is a fault condition. If there is a short, current increases so that  $I_{DD} > I_{DDH} (\max)$ , outside the valid  $I_{DDH}$  range. If there is an open, the current lowers below the  $I_{DDL} (\min)$ , outside the valid output current range. In this way, connectivity issues between the ECU and the sensor can easily be detected.

## 13. Typical Application

The typical application circuit is as follow,  $R_S=100\Omega$ ,  $C_P=100nF$

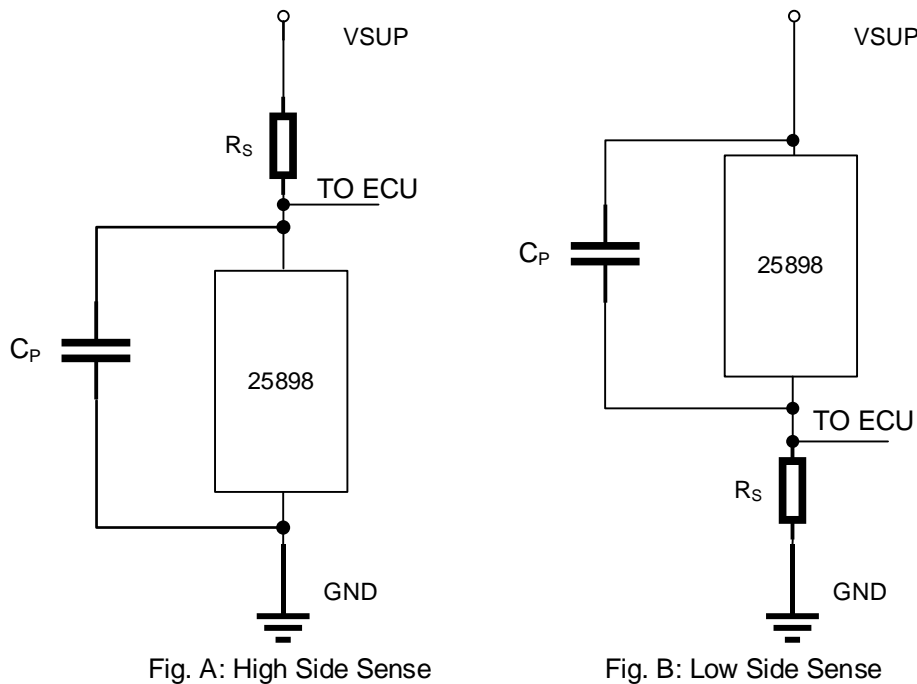
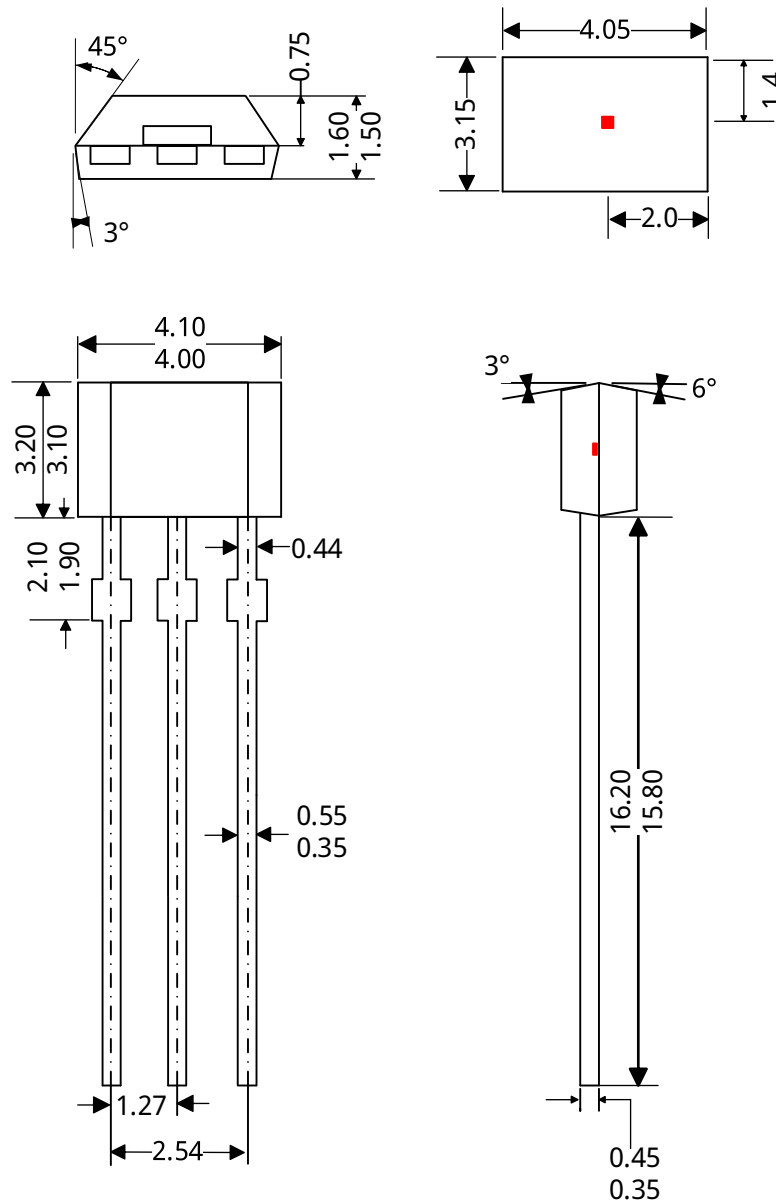

Fig.6 The Typical Application Circuit

The SC25898 contains an on-chip voltage regulator and can operate over a wide supply voltage range. In applications that operate the device from an unregulated power supply, transient protection must be added externally. For applications using a regulated line, EMI/RFI protection may still be required. It is recommended to shunt capacitor  $C_P$  (From 10nF to 100nF) to the ground as close as possible to  $V_{DD}$  power supply, a typical value is 100nF. At the same time, the external series resistor  $R_S$  is needed, the typical value is 100 $\Omega$ . In addition, when using CUB packaging, since the CUB packaging chip already integrates a 100nF capacitor internally, the external  $C_P$  capacitor can be omitted when designing the overall sensor scheme, thus achieving a PCB-less solution without PCBA requirements.

## 14. Package Information UA

### TO-92S-S2 PACKAGE OUTLINE DIMENSIONS



**Notes:**

(1) All unit in mm.

(2) Dimension does not include mold flash, protrusions or gate burrs.

(3) Allowable dambar protrusion shall be in excess at maximum material condition.

If no tolerance is specified, the dimension shall be theoretical reference value and shall not represent the exact dimension for actual measurement.

## 15. Package Information CUB

### 3-Terminal TO-92S Package

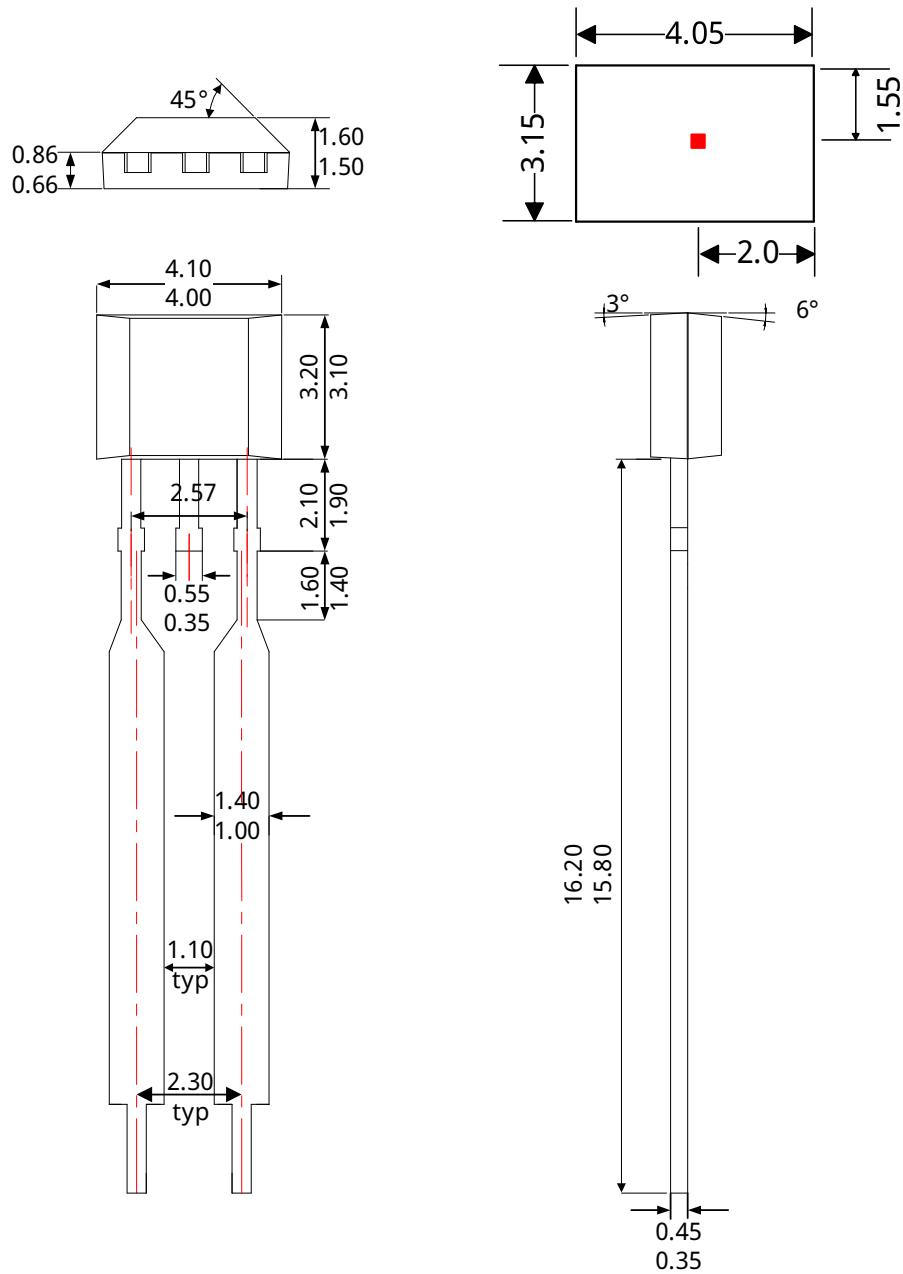

**Notes:**

- (1) All unit in mm.
- (2) Dimension does not include mold flash, protrusions or gate burrs.
- (3) Allowable dambar protrusion shall be in excess at maximum material condition.

If no tolerance is specified, the dimension shall be theoretical reference value and shall not represent the exact dimension for actual measurement.

## 16. Revision History

Revision	Date	Description
Rev.E0.1	2024-12-22	Preliminary datasheet
Rev.A1.0	2025-07-14	Official version release

## Notice and Disclaimer

The information, data, and specifications set out in this document (the "Document") are provided "AS IS" and for reference purposes, they shall not be construed as any warranty or authorization, whether express or implied, including but not limited to warranties of accuracy, completeness, merchantability, fitness for a particular purpose, or non-infringement of any third party's intellectual property rights.

Users of this Document are solely responsible for the selection, use, and application of SEMIMENT products, as well as for ensuring the safety of such applications. Users shall comply with all applicable laws, regulations, and requirements related to the use of SEMIMENT products. Any application-related information or support that may be provided by SEMIMENT is for reference only and does not constitute any guarantee or liability.

The resources described in this Document are subject to change without notice. SEMIMENT grants permission to use these resources solely for the development of applications incorporating SEMIMENT products as described herein. Any other reproduction, distribution, or public display of these resources is prohibited without prior written consent. No license, express or implied, is granted under any SEMIMENT intellectual property rights or any third-party intellectual property rights.

You agree to defend, indemnify and hold harmless SEMIMENT and its representatives from and against any claims, damages, costs, losses, or liabilities arising from your use of these resources.

For the latest product information and technical support, please contact SEMIMENT ([www.semiment.com](http://www.semiment.com)).

**Copyright © Semiment Technology Co.,Ltd**